

# Cool SpaceRunner-LX800 PC/104-Plus CPU Board

## Technical Manual

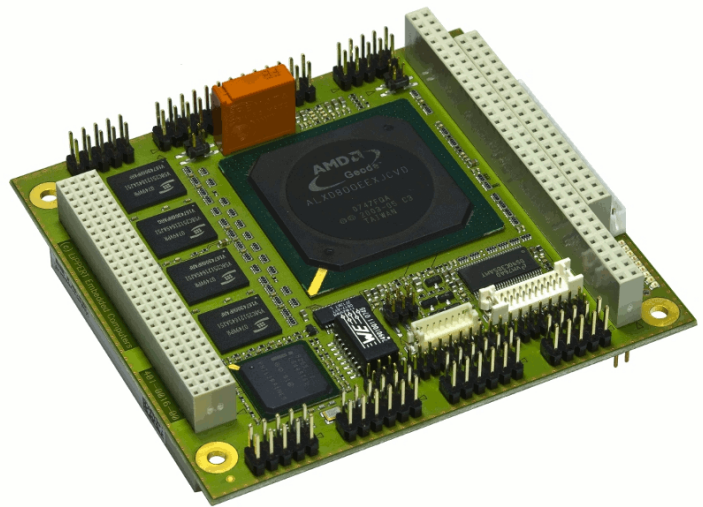

## *Technical Manual Cool SpaceRunner-LX800*

LiPPERT Document: TME-104P-CSR-LX800-R1V12.doc Revision 1.12

Copyright ©2011 LiPPERT Embedded Computers GmbH, All rights reserved

Contents and specifications within this manual are subject of change without notice.

### **Trademarks**

MS-DOS, Windows, Windows 95, Windows 98, Windows NT and Windows XP are trademarks of Microsoft Corporation. PS/2 is a trademark of International Business Machines, Inc. Intel and Solid State Drive are trademarks of Intel Corporation. Geode is a trademark of Advanced Micro Devices. PC/104 is a registered trademark of PC/104 Consortium. All other trademarks appearing in this document are the property of their respective owners.

### **Disclaimer**

Contents and specifications within this technical manual are subject of change without notice.

LiPPERT Embedded Computers GmbH provides no warranty with regard to this technical manual or any other information contained herein and hereby expressly disclaims any implied warranties of merchantability or fitness for any particular purpose with regard to any of the foregoing. LiPPERT Embedded Computers GmbH assumes no liability for any damages incurred directly or indirectly from any technical or typographical errors or omissions contained herein or for discrepancies between the product and the technical manual. In no event shall LiPPERT Embedded Computers GmbH be liable for any incidental, consequential, special, or exemplary damages, whether based on tort, contract or otherwise, arising out of or in connection with this user's guide or any other information contained herein or the use thereof.

## Table of Contents

<b>1</b>	<b>Overview</b>	<b>1</b>
1.1	Introduction .....	1
	Features .....	1
	Block Diagram .....	2
1.2	Ordering Information .....	3
	Cool SpaceRunner-LX800 Models .....	3
	Cable Sets and Accessories .....	3
1.3	Specifications .....	4
	Electrical Specifications .....	4
	Environmental Specifications .....	4
	Mean Time Between Failures .....	4
1.4	Mechanical .....	5
<b>2</b>	<b>Getting Started</b>	<b>6</b>
2.1	Connector Locations .....	6
	Top .....	6
	Bottom .....	7
2.2	Jumper Locations .....	8
2.3	LED indicators .....	9
2.4	Hardware Setup .....	10
<b>3</b>	<b>Module Description</b>	<b>11</b>
3.1	Processor .....	11
3.2	Companion .....	12
3.3	Graphics-Controller .....	13
	VGA Connector .....	14
	LVDS Configuration .....	15
	LVDS Connector .....	15
	LVDS Color Mapping .....	16
	Backlight Connector .....	16
	Display Voltage Jumpers .....	17
3.4	EIDE Solid State Drive .....	17

<b>3.5</b>	<b>Ethernet Controller</b> .....	<b>18</b>
	Ethernet Interface .....	18
<b>3.6</b>	<b>On Board Power Supply</b> .....	<b>19</b>
	Power Connector .....	19
<b>3.7</b>	<b>EIDE Port</b> .....	<b>20</b>
	EIDE Connector .....	20
<b>3.8</b>	<b>PS/2 Interface</b> .....	<b>21</b>
	Keyboard and Mouse Connector .....	21
<b>3.9</b>	<b>USB 2.0 Ports</b> .....	<b>21</b>
	USB 2.0 Connector 0.....	22
	USB 2.0 Connector 1/2/3.....	22
<b>3.10</b>	<b>Serial Ports</b> .....	<b>23</b>
	COM1/2 Connector.....	23
	RS485-Termination Jumpers .....	24
<b>3.11</b>	<b>Parallel Port LPT</b> .....	<b>24</b>
	LPT Connector .....	25
<b>3.12</b>	<b>Speaker</b> .....	<b>26</b>
<b>3.13</b>	<b>External Power-Button</b> .....	<b>26</b>
<b>3.14</b>	<b>Reset-In Signal</b> .....	<b>27</b>
<b>3.15</b>	<b>Internal Battery</b> .....	<b>27</b>
<b>3.16</b>	<b>External Battery</b> .....	<b>27</b>
<b>3.17</b>	<b>PC/104-Plus Bus Interface</b> .....	<b>28</b>
	PC/104 Plus Bus Connector .....	29
<b>3.18</b>	<b>PC/104 Bus Interface</b> .....	<b>30</b>
	PC/104 Bus Connector .....	30
<b>3.19</b>	<b>BIOS Recovery</b> .....	<b>31</b>
<b>4</b>	<b>Using the Module</b> .....	<b>32</b>
<b>4.1</b>	<b>Watchdog</b> .....	<b>32</b>
<b>4.2</b>	<b>LEMT functions</b> .....	<b>32</b>
<b>4.3</b>	<b>BIOS</b> .....	<b>33</b>
	Battery Jumper .....	33
	Configuring the XpressROM BIOS .....	33

Trouble Shooting BIOS Settings .....	41
<b>4.4 Drivers .....</b>	<b>42</b>
<b>4.5 Programming Examples .....</b>	<b>43</b>
LIVE-LED .....	43
Watchdog .....	44
Reading Temperatures .....	45
Reading Voltages .....	46
<b>5 Address Maps .....</b>	<b>47</b>
<b>5.1 Memory Address Map .....</b>	<b>47</b>
<b>5.2 I/O Address Map .....</b>	<b>48</b>
<b>5.3 Interrupts .....</b>	<b>49</b>
<b>5.4 DMA Channels.....</b>	<b>49</b>
<b>5.5 PC/104 Bus Address Space .....</b>	<b>50</b>
<b>Appendix A, Contact Information .....</b>	<b>A</b>
<b>Appendix B, Additional Information .....</b>	<b>B</b>
<b>Appendix C, Getting Help .....</b>	<b>C</b>
<b>Appendix D, Revision History .....</b>	<b>D</b>

## Acronyms

ACPI	Advanced Configuration and Power Management Interface
AES	Advanced Encryption Standard
APM	Advanced Power Management
ATA	Advanced Technology Attachment
BIOS	Basic Input Output System
BPP	Bits Per Pixel
CD	Compact Disc
COM	Communication Equipment
CPU	Central Processing Unit
CRT	Cathode Ray Tube
CSR	Cool SpaceRunner
DAC	Digital-to-Analog-Converter
DDR	Double Data Rate
DMA	Direct Memory Access
DOT	Dynamic Overclocking Technology
EIDE	Enhanced Integrated Device Electronics
EMC	Electromagnetic Compatibility
ETH	Ethernet
FIFO	First In First Out
FPU	Floating Point Unit
FWH	Firmware Hub
GPIO	General Purpose Input Output
HDD	Hard Disk Drive
I <sup>2</sup> C	Inter-Integrated Circuit
IP	Internet Protocol
ISA	Industry Standard Architecture
LCD	Liquid Crystal Display
LEMT	LiPPERT Enhanced Management Technology
LED	Light Emitting Diode
LPC	Low Pin Count
LVDS	Low Voltage Differential Signaling
MAC	Media Access Control
MMU	Memory Management Unit
PCI	Peripheral Component Interconnect
PHY	Physical Interface
PLL	Phase-Locked Loop
PS/2	Personal System/2
PWR	Power
SMB	System Management Bus
SMC	System Management Controller
SPI	Serial Peripheral Interface
SSD	Solid State Drive
SVGA	Super Video Graphics Array
TCP	Transmission Control Protocol
TLB	Translation Look-aside Buffer
UART	Universal Asynchronous Receiver Transmitter
USB	Universal Serial Bus
UDMA	Ultra-Direct Memory Access
UDP	User Datagram Protocol
VGA	Video Graphics Array
WDOG	Watchdog

# 1 Overview

## 1.1 Introduction

The Cool SpaceRunner-LX800 is a CPU-board for especially designed with rugged appliances in mind. It allows the design of devices without moving parts. Additional resilience comes from the used through-hole connectors.

The PC/104-Plus board with AMD's Geode™ LX processor has a very good performance to power ratio. The board comprises all peripherals needed for an embedded PC on a small 3.775" by 4.050" printed circuit board. It is fully plug-in compatible with the Cool SpaceRunner 2, except that the Flat Panel connector is replaced with three USB 2.0 ports.

The Cool SpaceRunner-LX800 integrates a powerful yet efficient AMD Geode™ LX800 processor together with a CS5536 I/O companion and a Super I/O chip to form a complete PC, with all the standard peripherals already onboard. There is a graphics controller with VGA and LVDS adapters to connect different sorts of display terminals. Backlighting is provided for LCD modules too.

A fast 100/10BaseT Ethernet port, two RS232/RS422/RS485 serial ports, and four USB 2.0 host ports handle the communication with external devices. There are PS/2 connectors for keyboard and mouse as well as a parallel printer port available. An IDE ATA100 adapter allows connection of hard disk or CD drives. Applications that require non-moving storage can use the integrated Solid State Drive.

There is Solid State Drive (SSD) integrated, which is connected to the ATA-controller.

System expansion can easily be realized over PC/104, PC/104-Plus and I<sup>2</sup>C bus connectors.

The Cool SpaceRunner-LX800 is powered by a 5V-only supply and supports ACPI, advanced power management and PCI power management. Security critical applications take advantage of the Geode LX800 processor, too. It has an on-chip AES 128-bit crypto acceleration block capable of 44 Mbps throughput on either encryption or decryption. The AES block runs asynchronously to the processor core and is DMA based.

The Cool SpaceRunner-LX800 runs DOS, Windows, Linux and VxWorks operating systems.

### *Features*

#### **CPU**

- AMD Geode™ LX 800@0,9W (500MHz)
- Cache Memory with:
  - 64 KB/64 KB level 1 I/D caches
  - TLB (Translation Look-aside Buffer):
    - 128 KB level 2 cache
  - Efficient Prefetch

#### **Chipset**

- AMD CS5536 companion device

#### **Interfaces**

- Ethernet 10/100BaseT
- ATA-6 EIDE (Ultra DMA-100)
- PS/2 Keyboard/Mouse
- 4 x USB 2.0 ports
- 2 x RS232/RS485/RS422, software selectable
- 1 x parallel port

#### **Main Memory**

- soldered 256 MB DDR SDRAM 400 MHz

#### **Extension slots**

- 1 x 32-bit PC/104-Plus
- 1 x 16-bit PC/104 with full DMA capability
- SVGA monitor
- 18/24 Bit LVDS for displays
- MISC signals: external power button, I<sup>2</sup>C bus, speaker, external reset button, external battery connector
- Power supply
- Solid State Drive on EIDE

Other configurations are possible at high volumes.

**Block Diagram**

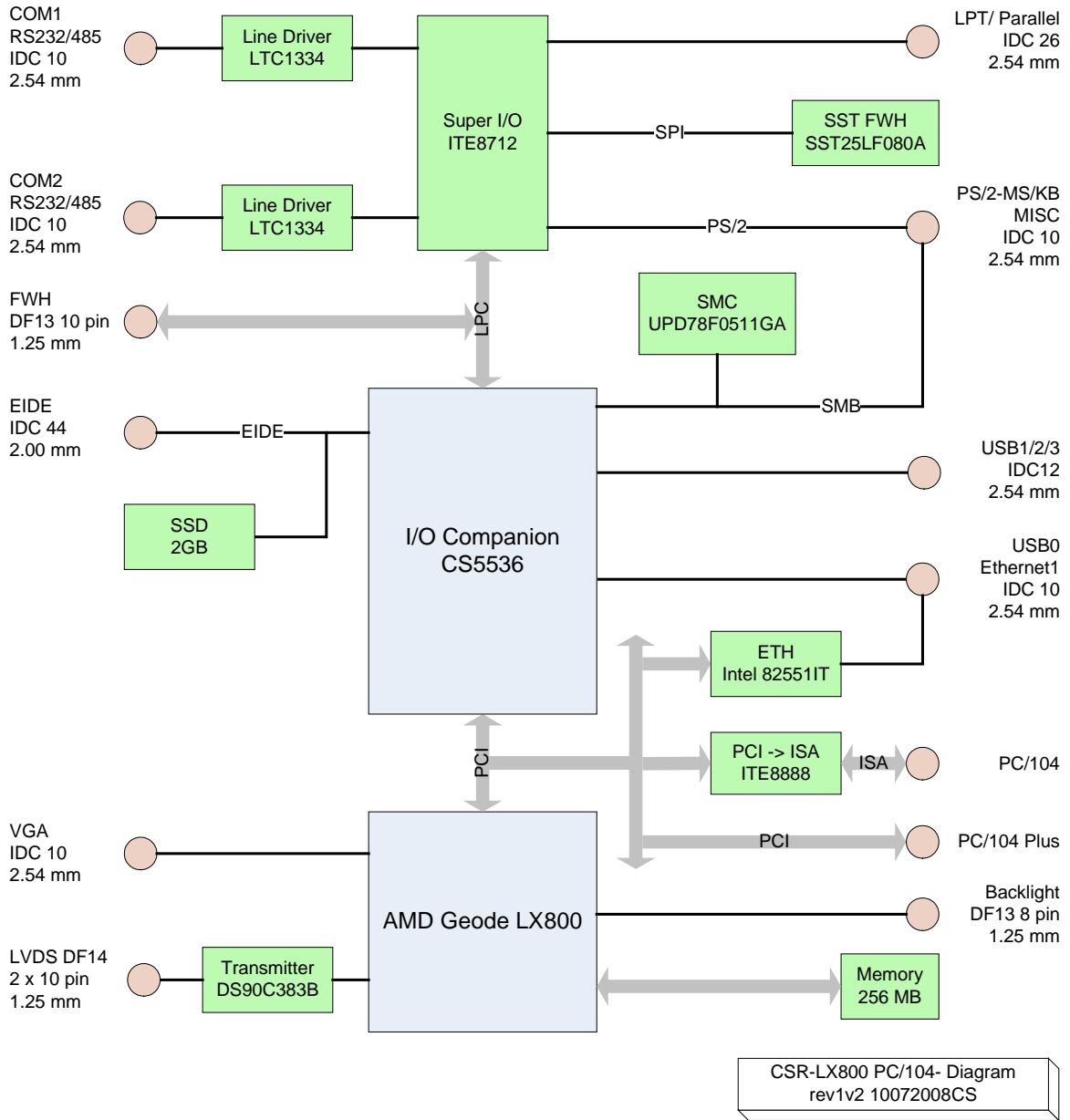

## 1.2 Ordering Information

### *Cool SpaceRunner-LX800 Models*

Order number	Description
903-0019-10	Cool SpaceRunner-LX800 with LCD+VGA-CRT, AMD GEODE LX800@0.9W (500 MHz), low power consumption, 256MB DDR SDRAM, 4x USB2.0, IrDA, RTC, Battery, EIDE, 3x COM, LPT (EPP/EPC), PS/2 Keyboard, PS/2 Mouse, WDOG, LEMT, PC/104 bus, PC/104+ bus, VGA controller and LVDS Interface, Fast Ethernet 100/10BaseT, EIDE 2 GB SSD  Operating temperature range: -40°C...+85°C

### *Cable Sets and Accessories*

There are some options offered for the Cool SpaceRunner-LX800.

Order number	Description
763-0014-10	Adapter Cable Set Power, PS/2 keyboard and mouse, Ethernet and USB, VGA-CRT, 3x USB, COM1, COM2, LPT, IDE (44 pin, 2mm), cable adapter 2.5" > 3.5", adapter 3.5" > 2.5"

## 1.3 Specifications

### *Electrical Specifications*

Supply voltage	+5 V DC
Rise time	< 10 ms
Supply voltage tolerance	± 5%
Inrush current	6.5 A, 25µs
Supply current	maximal 0.95 A (Memtest86 v1.70) <sup>1</sup> typical 0.6 A (Windows XP idle mode) typical 0.2 A (suspend to ram mode)

### *Environmental Specifications*

#### *Operating:*

Temperature range	-20 ... 60 °C (standard version) -40 ... 85 °C (extended version)
Temperature change	max. 10K / 30 minutes
Humidity (relative)	10 ... 90 % (non-condensing)
Pressure	450 ... 1100 hPa

#### *Non-Operating/Storage/Transport:*

Temperature range	-40 ... 85 °C
Temperature change	max. 10K / 30 minutes
Humidity (relative)	5 ... 95 % (non-condensing)
Pressure	450 ... 1100 hPa

### *Mean Time Between Failures*

MTBF at 25°C	294 173 hours
--------------	---------------

---

<sup>1</sup> With that tolerance is not mentioned that all plugged devices are running with.

<sup>2</sup> That rate of current is possible when only monitor, mouse and keyboard are plugged. If there are connected additional peripheral devices the current rises up.

## 1.4 Mechanical

Dimensions (L x W)	95.9 mm x 90.2 mm (including I/O extension)
Height	max. 14 mm on top side above PCB max. 12 mm on bottom side above PCB
Weight	100 g
Mounting	4 mounting holes



**Note:** It is strongly recommend using plastic spacers instead of metal spacers to mount the board. With metal spacers, there is a possible danger to create a short circuit with the components located around the mounting holes. This can damage the board!

TOP

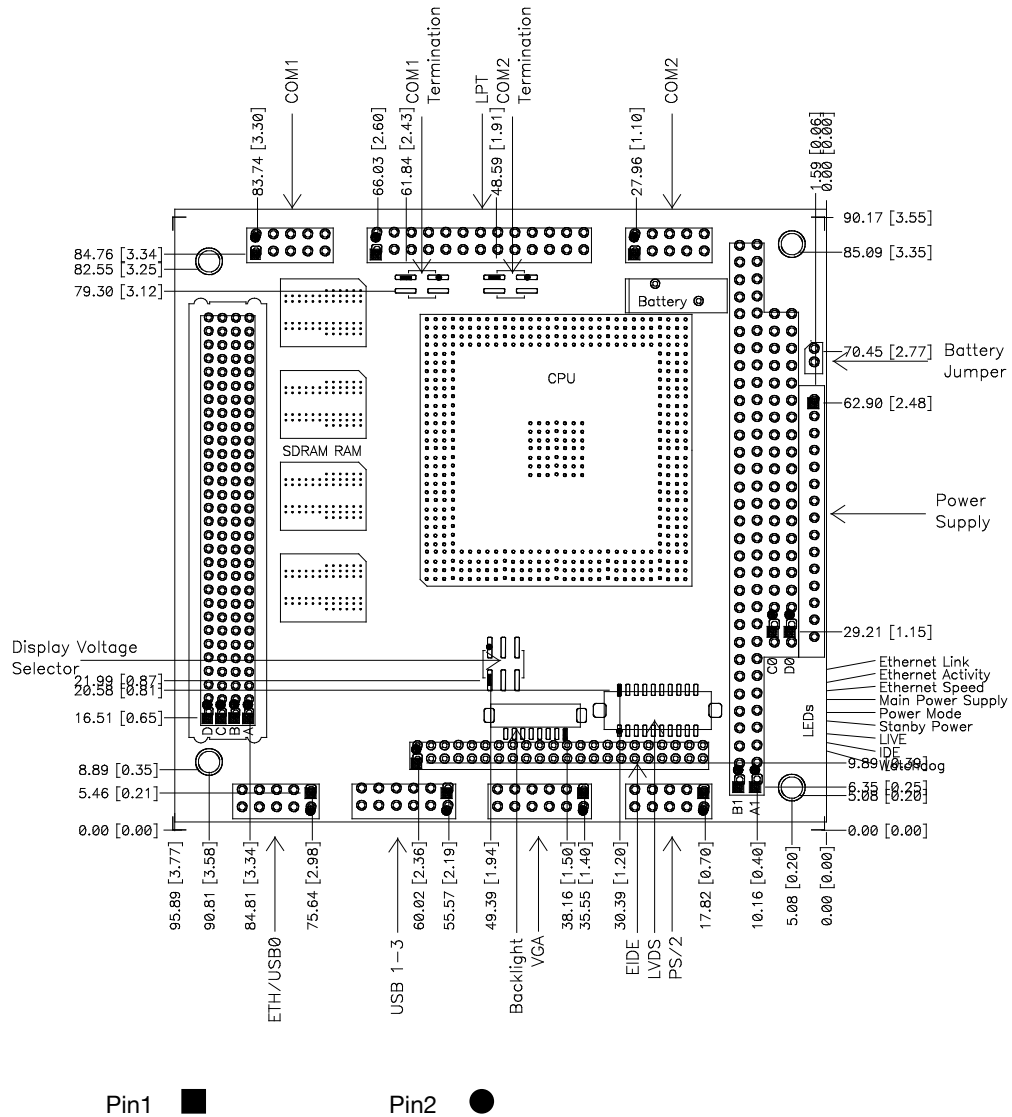

## 2 Getting Started

### 2.1 Connector Locations

*Top*

(Click on the blue font to reach the right chapter.)

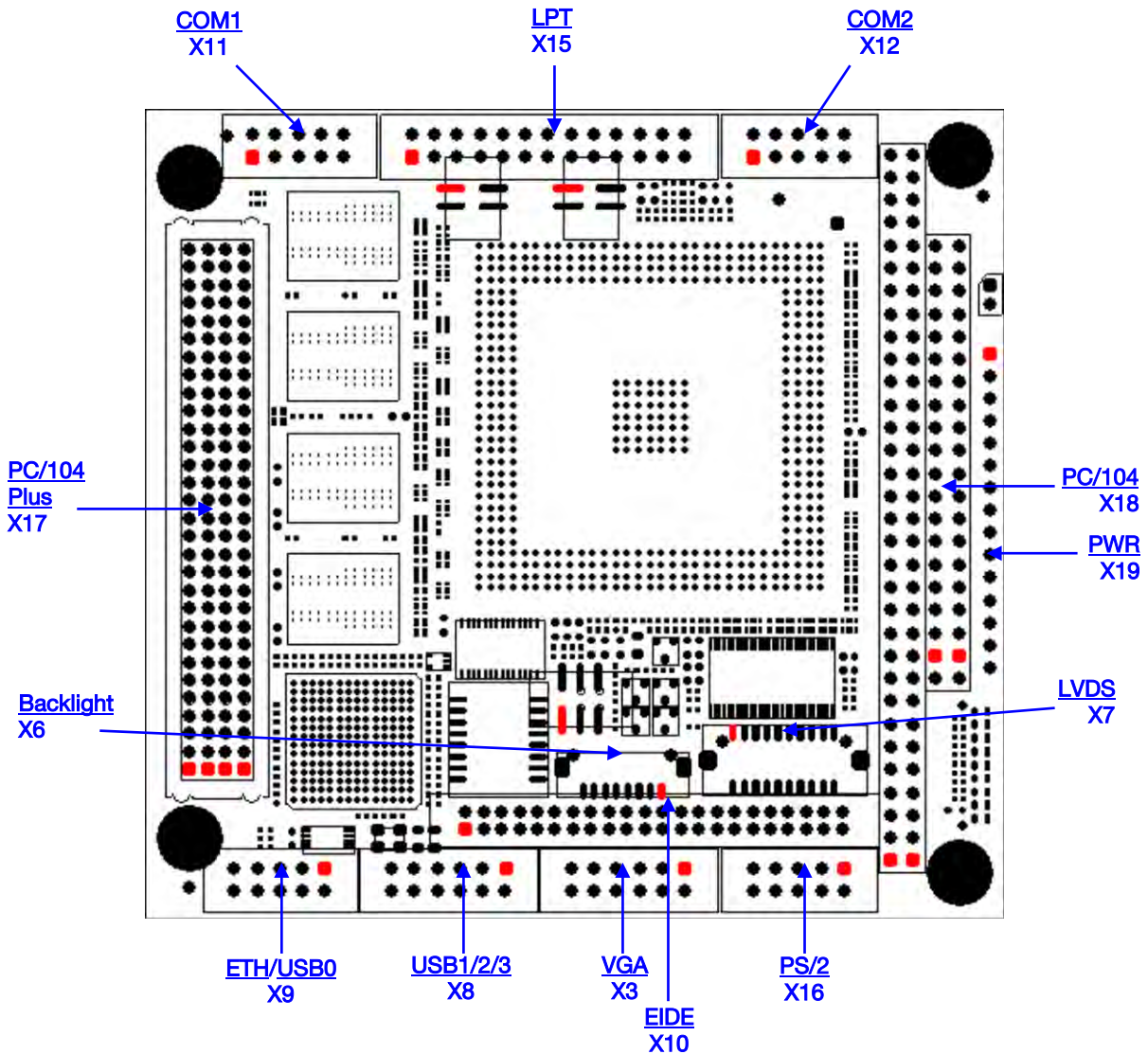

The connectors' pin 1 is marked **RED**

*Bottom*

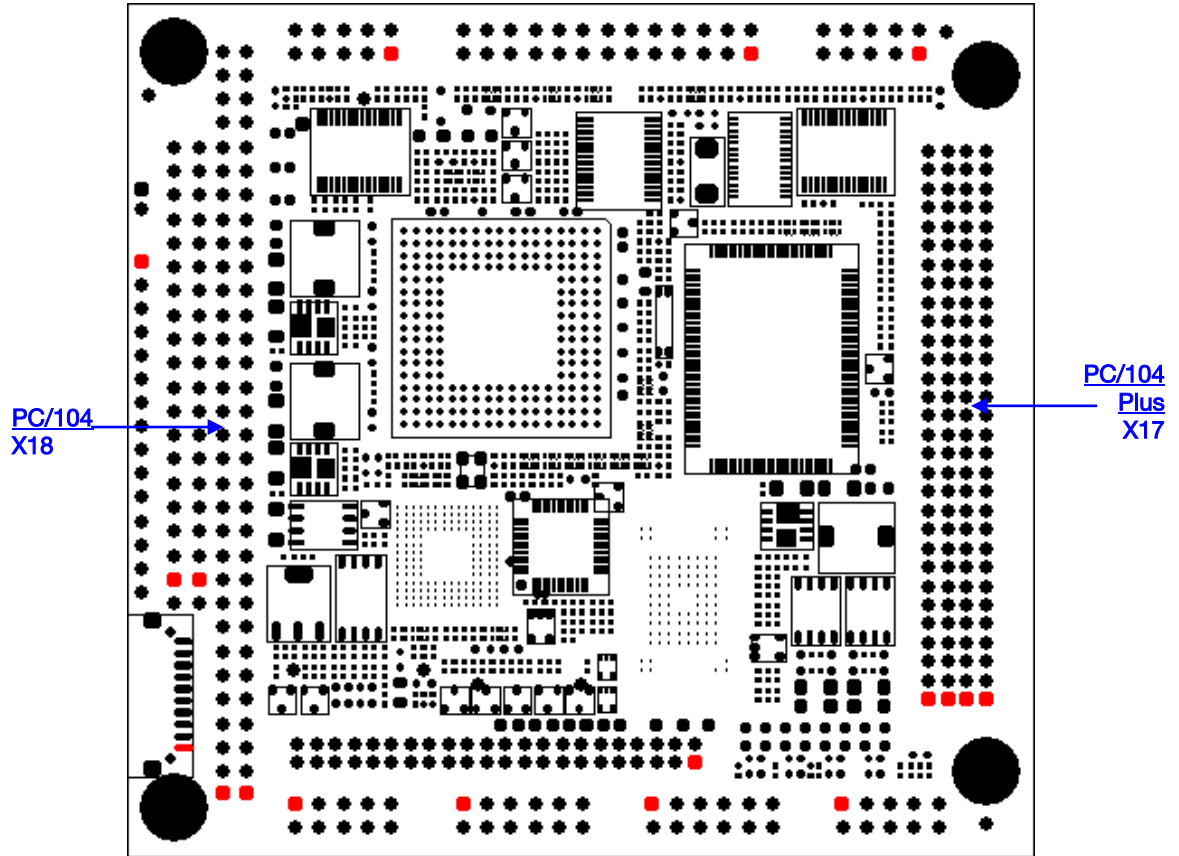

The connectors' pin 1 is marked **RED**

## 2.2 Jumper Locations

(Click on the blue font to reach the right chapter.)

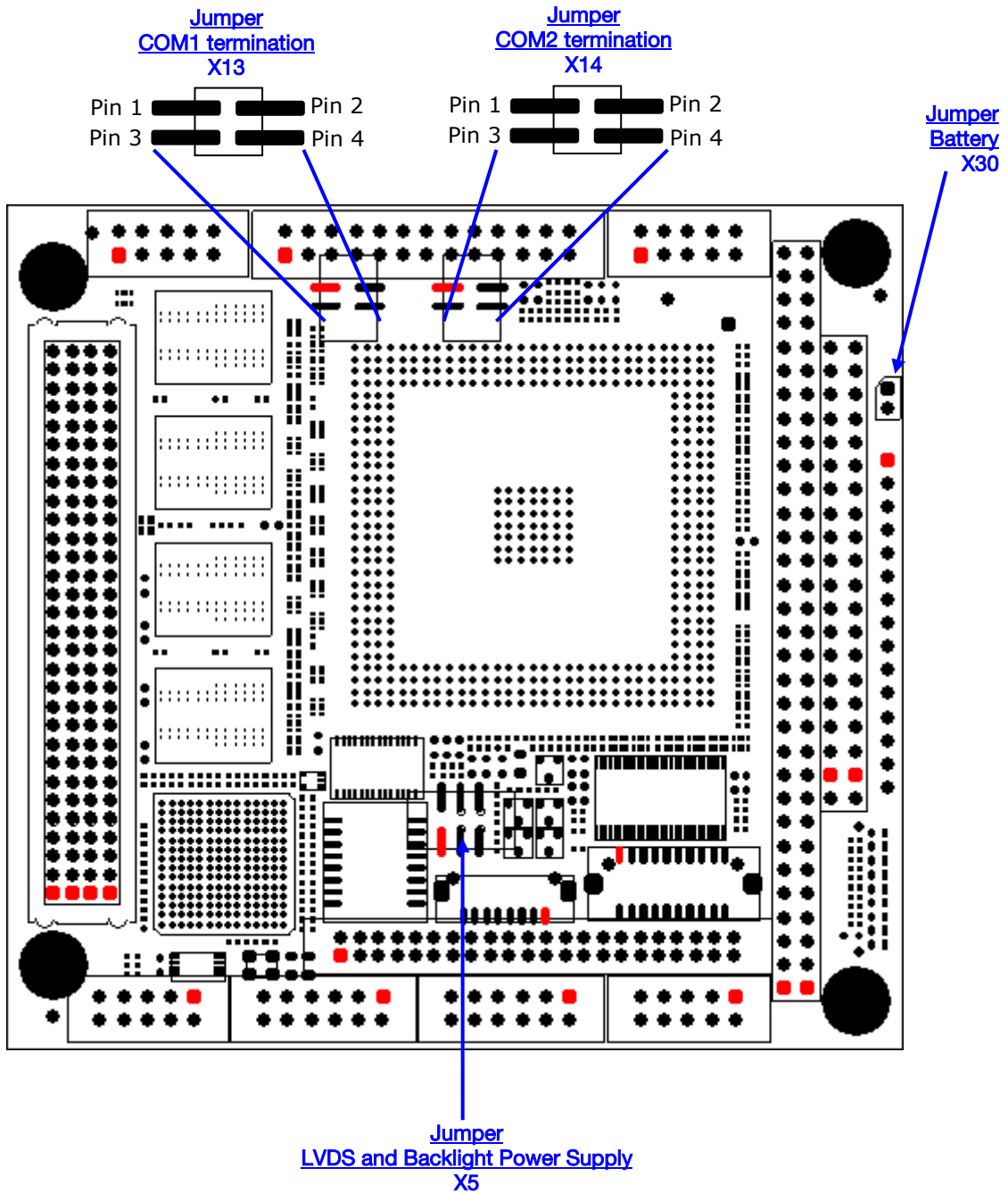

## 2.3 LED indicators

The onboard LED indicators provide a very comfortable way to check the board's status. The boot success, power status, IDE accesses, Watchdog and Ethernet accesses are all visible.

The LED indicators are located on top of the board, near the PC/104 connector.

<u>LINK</u>	Green LED shows the Ethernet Link status.
<u>ACT</u>	Red LED flashes at Ethernet activity.
<u>Speed</u>	Yellow LED lights up if 100Mbit connection is established.
<u>MAIN</u>	Green LED lights up when Main Power is supplied.
<u>PM</u>	Power Mode Green LED is constantly lit if the boot process is complete and the board is running normally. LED flashes when board goes in suspend to ram mode.
<u>SBY</u>	Green LED lights up when Standby Power is supplied.
<u>LIVE</u>	Red LED is on at startup while the board executes the BIOS power on self test (POST). After that it is freely usable by application programs. Chapter "LIVE-LED" shows a small sample program how to control it.
<u>IDE</u>	Yellow LED flashes when IDE activity is recognized.
<u>WD</u>	Red LED lights up when Watchdog was triggered. Can only be reset by a power off sequence.

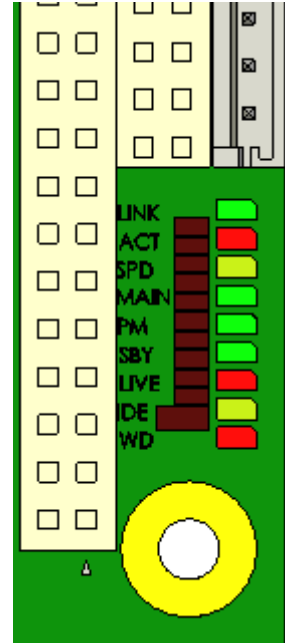

## 2.4 Hardware Setup

---



**Caution**

Be sure to observe the EMC security measures. Make sure you are always at the same potential as the module.

---



**Caution**

Never connect or disconnect peripherals like HDD's, PCI, and ISA boards while the board's power supply is connected and switched on!

---

Use the cable set provided by LIPPERT to connect the Cool SpaceRunner-LX800 to a VGA monitor. Connect either PS/2 or USB keyboard or mouse, respectively. Use the 44-wire cable to connect the hard disk. Make sure that the pins match their counterparts correctly and are not twisted! If you plan to use additional other peripherals, now is the time to connect them, too.

Set the "Jumper Battery" that it has contact with both pins. The location can be found on chapter 2.2.

Connect a 5 volt power supply to the power connector and switch the power on.

---



**Note**

In continuous mode there only about 1 amp necessary, but at power on there are more than 6,5 A inrush current required.

---

The display shows the BIOS messages. If you want to change the standard BIOS settings, press the <F1> key to enter the BIOS menu. See chapter 4.3 for setup details.

If you need to load the BIOS default values, they can be automatically loaded at boot time. See chapter "Trouble Shooting BIOS Settings", about how to do it.

The Cool SpaceRunner-LX800 boots from CD drives, USB floppy, USB stick, or hard disk. Provided that any of these is connected and contains a valid operating system image, the display then shows the boot screen of your operating system.

The Cool SpaceRunner-LX800 does not need any cooling measures, neither at standard environment temperatures from -20 °C ... +60 °C nor in the extended range of -40 °C ... +85 °C.

### 3 Module Description

#### 3.1 Processor

The AMD Geode LX 800@0.9W processor delivers one of the best performance-per-watt figures in the industry, providing x86 power and versatility to embedded products. Its architecture and high level of integration guarantees longer battery life and allows very small designs, while delivering full x86 functionality.

The AMD Geode LX 800 processor consumes a maximum power of 3.9W and 1.8W typical at 500 MHz, enabling systems that only need to be passively cooled.

The x86 compatibility allow designers to focus on developing end products that efficiently meet consumer needs without being concerned with software porting or compatibility issues.

Coupled with the AMD Geode™ CS5536 companion device, the combined chipset, which operates at 1.9W typical at 433MHz and at 2.4W typical at 500MHz, offers a complete set of features that deliver full desktop functionality to embedded and portable devices.

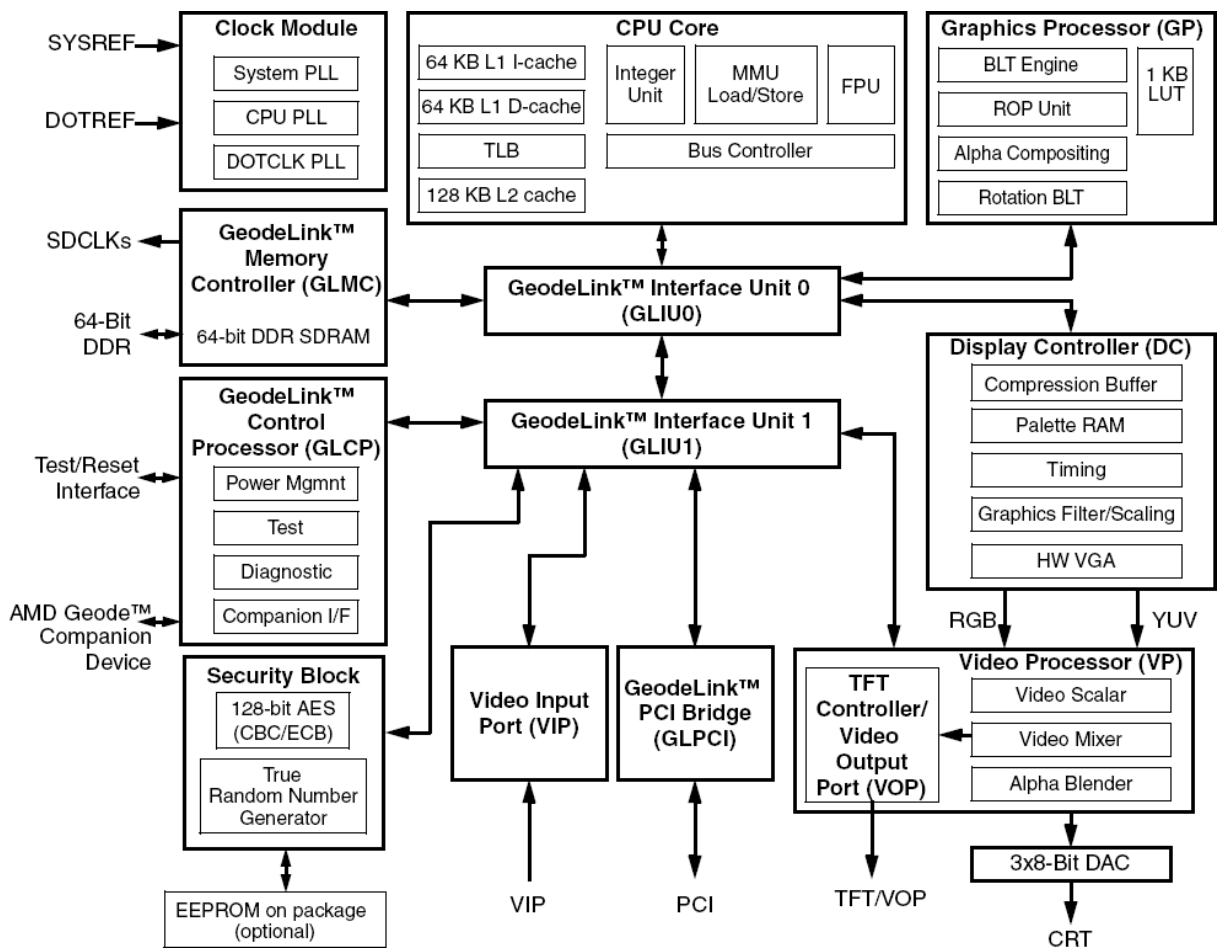

Internal block diagram of the LX 800 processor

Processor functional blocks are

- CPU Core
- GeodeLink™ Control Processor
- GeodeLink Interface Units
- GeodeLink Memory Controller
- Graphics Processor
- Display Controller
- Video Processor
- Video Input Port
- GeodeLink PCI Bridge
- Security Block

For further information please refer to the data book of the AMD Geode™ LX 800

## 3.2 Companion

AMD Geode™ CS5536 companion device

The AMD Geode™ CS5536 companion device is designed to work with an integrated processor North Bridge component such as the AMD Geode™ GX/LX processor. Together, the Geode GX/LX processor and Geode CS5536 companion device provide a system-level solution well suited for the high-performance and low-power needs of a host of embedded devices including digital set-top boxes, mobile computing devices, thin client applications, and single board computers.

The internal architecture uses a single, high-performance modular structure based on GeodeLink™ architecture. This architecture yields high internal speed (over 4 GB/s) data movement and extremely versatile internal power management. The GeodeLink™ architecture is transparent to application software. Communication with the Geode GX/LX processor is over a 33/66 MHz PCI bus.

The Geode CS5536 companion device incorporates many I/O functions, including some found in typical Super-I/O chips, simplifying many system designs. Since the graphics subsystem is entirely contained in the Geode GX/LX processor, system interconnect is simplified. The device contains state-of-the-art power management that enables systems, especially battery powered systems, to significantly reduce power consumption.

Audio is supported by an internal controller, designed to connect to multiple AC97 compatible codecs. An IR (infrared) port supports all popular IR communication protocols. The IR port is shared with one of two industry-standard serial ports that can reach speeds of 115.2 kbps. An LPC (low pin count) port is provided to facilitate connections to a Super-I/O should additional expansion, such as a floppy drive, be necessary, and/or to an LPC ROM for the system BIOS

The hard disk controller is compatible to the ATA-5 specification. The bus mastering IDE controller includes support for two ATA-compliant devices on one channel. The CS5536 companion device provides four Universal Serial Bus (USB) 2.0 compliant ports, supporting low speed, full speed, and high speed connections. All four ports are individually automatically associated with either the Open Host Controller Interface (OHCI) or the Enhanced Host Controller Interface (EHCI) depending on the attached device type. A real-time clock (RTC) keeps track of time and provides calendar functions.

A suite of 82xx devices provides the legacy PC functionality required by most designs, including two PIC's (programmable interrupt controllers), one PIT (programmable interval timer) with three channels, and DMA (direct memory access) functions. The CS5536 companion device contains eight MFGPT's (multi-function general purpose timers) that can be used for a variety of functions. A number of GPIO's (general purpose input/outputs) are provided, and are assigned to system functions on power-up.

State-of-the-art power management features are attained with the division of the device into two internal power domains. The GPIO's and multi-function timers are distributed into each domain allowing them to act as wakeup sources for the device. The device provides full ACPI (Advanced Configuration Power Interface) compliance and supports industry-standard Wakeup and Sleep modes.

### 3.3 Graphics-Controller

The graphics controller is integrated in the Geode LX processor and does high performance 2D-graphics handling. CRT monitors can be used as well as LVDS displays. Therefore, two different connectors are on the board. It is possible to use a CRT and a LVDS display simultaneously (depends on drivers setting), but only with the same graphics content on both displays.

The Cool SpaceRunner-LX800 supports 3,3V and 5V LVDS displays with 18/24bit interfaces and unconventional signal configuration. The display type and resolution can be selected in BIOS setup: *Graphics Configuration*

#### SVGA Configuration

Resolution	Color Depth (bpp)	Refresh Rate (Hz)	Dot Clock (MHz)	Min. GLIU Frequency (MHz)
640 x 480	8, 16, or 24/32	60	25.175	75
	8, 16, or 24/32	70	28.560	75
	8, 16, or 24/32	72	31.500	75
	8, 16, or 24/32	75	31.500	75
	8, 16, or 24/32	85	36.000	75
	8, 16, or 24/32	90	37.889	400
	8, 16, or 24/32	100	43.163	400
800 x 600	8, 16, or 24/32	60	40.000	75
	8, 16, or 24/32	70	45.720	75
	8, 16, or 24/32	72	49.500	75
	8, 16, or 24/32	75	49.500	75
	8, 16, or 24/32	85	56.250	75
	8, 16, or 24/32	90	60.065	400
	8, 16, or 24/32	100	68.179	400
1024 x 768	8, 16 or 24/32	60	65.000	75
	8, 16, or 24/32	70	75.000	100
	8, 16, or 24/32	72	78.750	100
	8, 16, or 24/32	75	78.750	100
	8, 16, or 24/32	85	94.500	100
	8, 16, or 24/32	90	100.187	400
	8, 16, or 24/32	100	113.310	400
1152x864	8, 16, or 24/32	60	81.600	100
	8, 16, or 24/32	70	97.520	100
	8, 16, or 24/32	72	101.420	200
	8, 16, or 24/32	75	108.000	200
	8, 16, or 24/32	85	119.650	200
	8, 16, or 24/32	90	129.600	400
	8, 16, or 24/32	100	144.000	400
1280 x 1024	8, 16, or 24/32	60	108.000	200
	8, 16, or 24/32	70	129.600	200
	8, 16, or 24/32	72	133.500	200
	8, 16, or 24/32	75	135.000	200

Resolution	Color Depth (bpp)	Refresh Rate (Hz)	Dot Clock (MHz)	Min. GLIU Frequency (MHz)
	8, 16, or 24/32	85	157.500	200
	8, 16, or 24/32	90	172.800	400
	8, 16, or 24/32	100	192.000	400
1600 x 1200	8, 16, or 24/32	60	162.000	200
	8, 16, or 24/32	70	189.000	200
	8, 16, or 24/32	72	198.000	233
	8, 16, or 24/32	75	202.500	233
	8, 16, or 24/32	85	229.500	266
	8, 16, or 24/32	90	251.182	400
	8, 16, or 24/32	100	280.640	400
1920x1440	8, 16, or 24/32	60	234.000	266
	8, 16, or 24/32	70	278.400	400
	8, 16, or 24/32	72	288.000	400
	8, 16, or 24/32	75	297.000	400
	8, 16, or 24/32	85	341.349	400

**VGA Connector**

Connector type: IDC10 pin header 2.54 mm  
Matching connector: IDC10 pin female connector 2.54 mm

Pin	Signal	Pin	Signal
1	Red	2	GND
3	Green	4	GND
5	Blue	6	GND
7	HSYNC	8	GND
9	VSYNC	10	GND

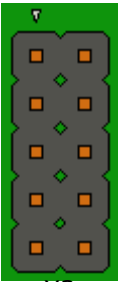

X3

## LVDS Configuration

The display options of LVDS are shown in the table:

Setting	Possible Values
Flat Panel Type	LVDS
Resolution	320x240, 640x480, 800x600, 1024x768, 1152x864, 1280x1024, 1600x1200
Data Bus Type	18/24 Bits, 2ppc
Refresh Rate	60 70, 72, 75, 85, 90, 100 Hz
HSYNC Polarity	High, Low
VSYNC Polarity	High, Low
LP Active Period	Active Only à only active during SYNC Free Running à always active
SHFCLK Active Period	Active Only à only active during SYNC Free Running à always active

To ease usage of these displays it's possible to select the display and backlight supply voltages with the onboard voltage selector jumpers. (Jumper LVDS and Backlight, see below)

## LVDS Connector

Connector type: Hirose DF13 2x 10-pin header

Matching connector: Hirose DF13-20DS-1.25C, part number 536-0555-6 00

Pin	Signal	Pin	Signal
2	SW-VDD <sup>1</sup>	1	SW-VDD
4	GND	3	GND
6	TX3+	5	TX3-
8	TXCLK-	7	GND
10	GND	9	TXCLK+
12	TX2+	11	TX2-
14	TX1-	13	GND
16	GND	15	TX1+
18	TX0+	17	TX0-
20	DDC DATA	19	DDC CLK

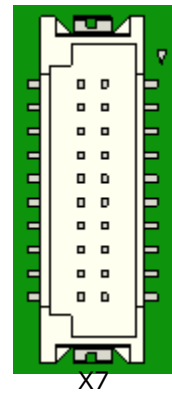

<sup>1</sup> 1.0 A is the maximum current for each pin

## LVDS Color Mapping

Diff.pairs	Previous cycle	Next cycle
Clock		
TX3		
TX2		
TX1		
TX0		

## Backlight Connector

Connector type:

Hirose DF13 8 pin

Matching connector:

Hirose DF13-8S-1.25C, part number 536-0007-0 00

Pin	Signal
1	+12 Volt
2	+12 Volt
3	+5 Volt
4	+5 Volt
5	EN
6	VCC
7	GND
8	GND

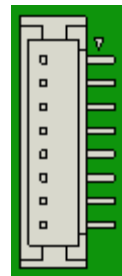

X6

· 0.5 A is the maximum current for each pin

· That voltage can be selected using the jumper "Backlight", shown on next page.

### Display Voltage Jumpers

Jumper LVDS and Backlight

Connector type: IDC6 pin header 2.0 mm  
Matching part: 2.0 mm jumper

Use a 2 mm jumper between 1-3 or 3-5 to select the backlight voltage.

Use a 2 mm jumper between 2-4 or 4-6 to select the display voltage.

Pin	Signal	Pin	Signal
1	+12 Volt	2	+5 Volt
3	Backlight voltage	4	Display voltage
5	+ 5 Volt	6	+3.3 Volt



■ default jumper setting

Backlight		
Jumper	1-3	3-5
Power supply	+12V	+5V
LVDS		
Jumper	2-4	4-6
Power supply	+5V	+3.3V



**Note:** An arrow on the PCB marks Pin 1

### 3.4 EIDE Solid State Drive

On the top side of the board, the SSD is mounted. It can be used instead of a hard disk. Per default, it is defined as master but that can be changed in BIOS.

The SSD, manufactured by SST, is built as a flash storage organized of Single Level Cells (SLC). It can be erased over 100M times without losing capacity. The wear-leveling feature can increase that number, depending on the allocation of the disk space.

Product features:

Read Bandwidth	30 Mbytes/s
Write Bandwidth	20 Mbytes/s
Access time	0.2 ms
PATA Compatibility	ATA-5; PIO 0-4; DMA 0-2; UDMA 0-4
Power Control	Automatic power down during wait periods Automatic sleep mode during host inactivity
NAND Management	Active wear-leveling algorithm

### 3.5 Ethernet Controller

#### Intel 82551IT Fast Ethernet Controller

The 82551IT is an evolutionary addition to Intel's family of 8255x controllers. It provides excellent performance by offloading TCP, UDP and IP checksums and supports TCP segmentation off-load for operations such as Large Send. The 82551IT provides an extended operating temperature in addition to all of the same capabilities and features as the 82551ER to address applications requiring a wider operating temperature range.

Its optimized 32-bit interface and efficient scatter-gather bus mastering capabilities enable the 82551IT to perform high speed data transfers over the PCI bus. This capability accelerates the processing of high level commands and operations, which lowers CPU utilization. Its architecture enables data to flow efficiently from the bus interface unit to the 3 KB Transmit and Receive FIFO's, providing the perfect balance between the wire and system bus. In addition, multiple priority queues are provided to prevent data underruns and overruns.

The 82551IT includes both a MAC and PHY. It also has a simple interface to the analog front end, which allows cost effective designs requiring minimal board real estate. The 82551IT is pin compatible with the 82559 family of controllers and is offered with software that provides backwards compatibility with previous 8255xER controllers.

#### *Ethernet Interface*

The Ethernet connector is shared with USB 0 and I<sup>2</sup>C bus.

Connector type: IDC10 pin header 2.54 mm  
Matching connector: IDC10 pin female connector 2.54 mm

Pin	Signal	Pin	Signal
1	ETH1-TX+	2	ETH1-TX-
3	ETH1-RX+	4	SMB_DATA
5	SMB_CLK	6	ETH1-RX-
7	USB0+	8	USB0-
9	VCC_USB0	10	USB_GND

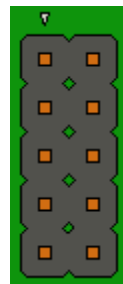

X9

### 3.6 On Board Power Supply

The on board power controllers generate all necessary voltages from the single supply voltage of 5 Volt. The generated 3.3 Volt is available at Backlight- and LVDS- connector.



**Note** This 3.3 V cannot be used to supply external electronic devices with high power consumption like other PC/104 boards or displays.

#### Power Connector

Connector type: JST B15B-EH-A 15 pin  
Matching connector: JST EHR-15 15 pin female connector

Pin	Signal (standard)	Signal (5V only)
1	+5 V	+5V
2	GND	GND
3	+5V	+5V
4	GND	GND
5	+5V	+5V
6	n.c.	n.c.
7	GND	GND
8	GND	GND
9	n.c.	n.c
10	n.c.	n.c
11	GND	GND
12	+12V	n.c
13	+12V	n.c
14	GND	GND
15	-12V	n.c



X19



**Note** The default cable adapter supports the connection of  $\pm 12V$  power supply. That pins are routed to the PC/104- , PC/104-plus bus as well as the backlight port. If the 5 V only power supply is required leave these pins open. The board can be supplied over the 5 V pins of the PC/104- or PC/104 plus bus too.

### 3.7 EIDE Port

An EIDE port is provided by the chipset to connect one drive. The connected device can be set as master and slave, depending on the SSD mode.. To enhance the performance, this port has a 100 MB/s IDE controller in UDMA mode per the ATA-5 specification The EIDE port is available on a standard 44-pin header (2 mm) for 2.5" hard disks.

Only one more EIDE device can be connected, one slot is reserved for the SSD.

#### *EIDE Connector*

Connector type IDC44 pin header 2.00 mm  
Matching connector: IDC44 pin female connector 2.00 mm

Pin	Signal	Pin	Signal
1	Reset#	2	GND
3	Data7	4	Data8
5	Data6	6	Data9
7	Data5	8	Data10
9	Data4	10	Data11
11	Data3	12	Data12
13	Data2	14	Data13
15	Data1	16	Data14
17	Data0	18	Data15
19	GND	20	NC
21	DRQ0	22	GND
23	Write	24	GND
25	Read	26	GND
27	Ready	28	CSEL
29	DACK0	30	GND
31	IRQ	32	IOCS16-
33	Address1	34	PD66
35	Address0	36	Address2
37	CS1	38	CS3
39	NC	40	GND
41	+5 Volt	42	+5 Volt
43	GND	44	GND

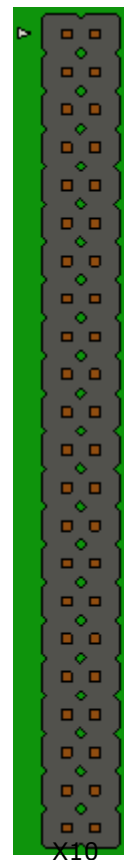

· 0,8 A is the maximum current for each pin

### 3.8 PS/2 Interface

PS/2-connectors for mouse and keyboard are shared with several system signals. An adapter cable for the PS/2 devices is available.

#### *Keyboard and Mouse Connector*

Connector type: IDC10 pin header 2.54 mm  
Matching connector: IDC10 pin female connector 2.54 mm

Pin	Signal	Pin	Signal
1	Speaker	2	Mouse Clock
3	Reset In	4	Mouse Data
5	KB Data	6	KB Clock
7	GND	8	+5 Volt Switched
9	Ext. Battery	10	Power Button

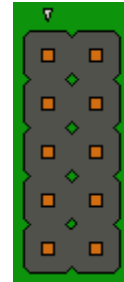

X16

### 3.9 USB 2.0 Ports

Four standard USB 2.0 host ports are provided with the Cool SpaceRunner-LX800. Three are located on the IDC12 header "USB". An adapter cable is available to use standard USB devices with this connector. The other one is located on the IDC10 header "Ethernet". A standard adapter cable is available, too.

It is possible to use an USB keyboard under MSDOS without special driver software.



**Note:** *Not all USB keyboard models are supported.*

0.5 A is the maximum current for each pin; power supply will be switched off in standby mode

**USB 2.0 Connector 0**

Connector type: IDC10 pin header 2.54 mm  
Matching connector: IDC10 pin female connector 2.54 mm

Pin	Signal	Pin	Signal
1	ETH1-TX+	2	ETH1-TX-
3	ETH1-RX+	4	SMB-DATA
5	SMB-CLK	6	ETH1-RX-
7	USB0+	8	USB0-
9	VCC_USB0	10	USB-GND

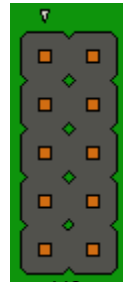

X9

**USB 2.0 Connector 1/2/3**

Connector type: IDC12 pin header 2.54 mm  
Matching connector: IDC12 pin female connector 2.54 mm

Pin	Signal	Pin	Signal
1	VCC_USB1	2	USB-GND
3	USB1+	4	USB1-
5	VCC_USB2	6	USB-GND
7	USB2+	8	USB2-
9	VCC_USB3	10	USB-GND
11	USB3+	12	USB3-

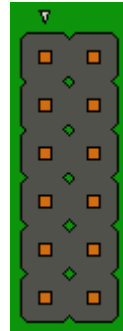

X8

· 0.5 A is the maximum current for that pin; power supply will be switched off in standby mode

### 3.10 Serial Ports

The maximum supported baud rates:

<u>RS485 mode</u>	1,5 Mbit/s *
<u>RS232 mode</u>	115 kbit/s

The serial ports are located on two IDC headers "COM1" and "COM2". Adapter cables with standard DSUB-9 male connectors are available. The ports either work in RS232 or RS485 mode, selectable in BIOS.

When entering **Serial and Parallel Device Configurations**, **COM Port 1 Mode** and **COM Port 2 Mode** can be selected. Termination resistors for RS485 Mode can be set with Jumpers on pin headers as described in this chapter.

To enable the transmitters of COM1 and COM2 in RS485 mode set the RTS# signal to '1'. Depending on your operating system driver's logic, this may mean setting a (non-inverted) RTS bit to '0' in your application software.

The serial ports are programmable in BIOS setup. When entering **Serial and Parallel Device Configurations**, configuration of the serial ports is accessible.

The following settings are possible for COM1 and COM2:

- Disabled
- 3F8 / IRQ4 (base address / interrupt channel)
- 2F8 / IRQ3 (base address / interrupt channel)
- 3E8 / IRQ4 (base address / interrupt channel)
- 2E8 / IRQ3 (base address / interrupt channel)

The modes can be switched between RS232 and RS485.

#### **COM1/2 Connector**

Connector type: IDC10 pin header 2.54 mm  
Matching connector: IDC10 pin female connector 2.54 mm

Pin	RS232	RS485	Pin	RS232	RS485
1	DCD	<i>Not used</i>	2	DSR	RXD+
3	RXD	RXD-	4	RTS	TXD+
5	TXD	TXD-	6	CTS	<i>Not used</i>
7	DTR	<i>Not used</i>	8	<i>Not used</i>	<i>Not used</i>
9	GND	GND	10	+5 Volt *	+5 Volt

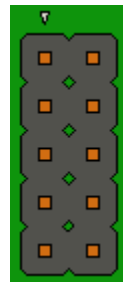

X11, X12

\* That baud rate requires changing registers manually, it is not supported by the default driver  
 \* 0.5 A is the maximum current for that pin

### RS485-Termination Jumpers

Connector type: IDC4 pin header 2.0 mm  
Matching connector: IDC4 pin female connector 2.0 mm

Use 2 mm jumpers to terminate lines correctly.

There are two jumpers COM1 and COM2, respectively.

The RS485 termination jumpers are located at the top of the printed circuit board, see chapter 2.2

Pin	Signal	Pin	Signal
1	TX+	2	TX-
3	RX+	4	RX-



When the jumper is set, the differential pairs are terminated with 120Ω between them. (e.g. RX+ and RX-)

Additionally, positive/negative receive lines are pulled up/down with 1kΩ to 5V/GND in order to protect the transceivers of the Cool SpaceRunner-LX800 from over voltage.

It is recommended to protect the ports of the external device in the same way!

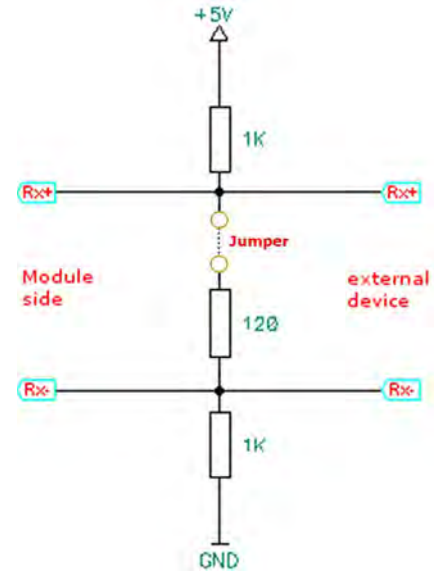

**Caution:** Termination Resistors **should not** be used in RS232 Mode! Otherwise, the serial ports will not work.

### 3.11 Parallel Port LPT

The parallel port is located on an IDC26 header. An adapter cable with a standard DSUB-25 female connector is available.

The parallel port is programmable in BIOS.

Entering **Motherboard Device Configuration** à **Serial and Parallel Device Configurations**, configuration of LPT is accessible.

LPT Parameter	Possible Settings
Base Address	Disabled, 0x378 0x3BC and 0x278 are not recommended, because of a possible conflict with the PCI to ISA Bridge
Mode	Compatible, PS/2 Bi-directional, EPP 1.7, EPP 1.9
IRQ	Disabled, IRQ 5, IRQ 7, IRQ 9, IRQ 10, IRQ 11
DMA	None, Channel 1, Channel 3

### LPT Connector

Connector type:

IDC26 pin header 2.54 mm

Matching connector:

IDC26 pin female connector 2.54 mm

Pin	Signal	Pin	Signal
1	Strobe	2	Auto LF
3	Data0	4	Error
5	Data1	6	Init
7	Data2	8	Select In
9	Data3	10	GND
11	Data4	12	GND
13	Data5	14	GND
15	Data6	16	GND
17	Data7	18	GND
19	ACK	20	GND
21	Busy	22	GND
23	Paper End	24	GND
25	Select	26	+5Volt "

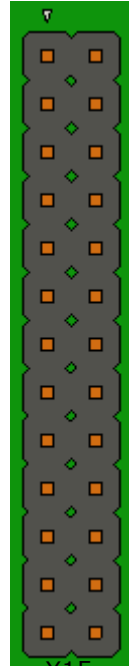

X15

---

" 0.5 A is the maximum current for that pin

### 3.12 Speaker

The speaker signal is located on the IDC10 Header PS/2. A standard PC Speaker can be connected between the signal SPEAKER and VCCKB.

Connector type: IDC10 pin header 2.54 mm  
Matching connector: IDC10 pin female connector 2.54 mm

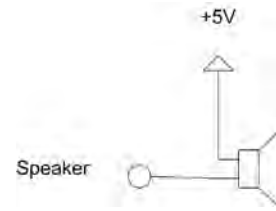

Pin	Signal	Pin	Signal
1	Speaker	2	Mouse Clock
3	Reset-In	4	Mouse Data
5	KB Data	6	KB Clock
7	GND	8	+5 Volt Switched *
9	Ext. Battery	10	Power Button (Default) Reset-In

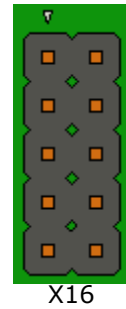

### 3.13 External Power-Button

The Power-Button signal is located on the IDC10 Header PS/2. To power up/down the board the signal Power-Button must be pulled to GND. It is not available in standard configuration.

Connector type: IDC10 pin header 2.54 mm  
Matching connector: IDC10 pin female connector 2.54 mm

Pin	Signal	Pin	Signal
1	Speaker	2	Mouse Clock
3	Reset-In	4	Mouse Data
5	KB Data	6	KB Clock
7	GND	8	+5 Volt Switched
9	Ext. Battery	10	Power Button

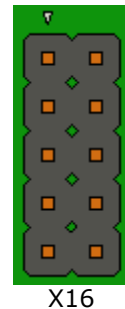

\* 0.5 A is the maximum current for each pin; power supply will be switched off in standby mode

### 3.14 Reset-In Signal

The "Reset-In" signal is located on the IDC10 Header PS/2. To reset the board, the signal "Reset-In" must be pulled to GND.

Connector type: IDC10 pin header 2.54 mm  
Matching connector: IDC10 pin female connector 2.54 mm

Pin	Signal	Pin	Signal
1	Speaker	2	Mouse Clock
3	Reset-In	4	Mouse Data
5	KB Data	6	KB Clock
7	GND	8	+5 Volt Switched
9	Ext. Battery	10	Power Button

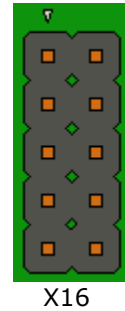

### 3.15 Internal Battery

On the board a soldered battery type CR1225 is used to keep RTC time and date running if the board is not powered. The battery can be connected or disconnected to the RTC with the battery jumper set to ON or OFF. As default on delivery the jumper is set to OFF. It is recommended to set this jumper if the board is used in the application and to remove the jumper if the board is stored for a longer period. This will prevent the battery from discharge.

### 3.16 External Battery

A connected battery should replace or support the mounted one to keep date and time active during the board is mechanical off.

It is recommended to use a model with 3 Volt, but it will also work with power suppliers up till 3,6 Volt.

The time and date will be lost if the power supplier falls down to 2,4 Volt.

For live time calculation there are 2 µA (25°C) needed when the board is not running.

That value can rise up with higher temperatures.

Connector type: IDC10 pin header 2.54 mm  
Matching connector: IDC10 pin female connector 2.54 mm

Pin	Signal	Pin	Signal
1	Speaker	2	Mouse Clock
3	Reset-In	4	Mouse Data
5	KB Data	6	KB Clock
7	GND	8	+5 Volt Switched
9	Ext. Battery	10	Power Button

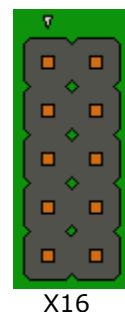

### 3.17 PC/104-Plus Bus Interface

The PC/104-Plus bus is a modification of the standard PCI bus. It allows all of the PC/104 features to be used, together with the high speed PCI bus.

The main features are:

- PC/104-Plus Bus slot, fully compatible with PCI version 2.2 specifications.
- Integrated PCI arbitration interface (32 bit wide, 3.3V).
- Translation of PCI cycles to ISA bus.
- Translation of ISA master initiated cycle to PCI.
- Support for burst read/write from PCI master.
- 33 MHz PCI clock.



**Note:** *The 3.3 V pins on the PC/104 Plus bus connector are not supplied by the onboard 3.3 V power supply. If a PC/104 Plus peripheral board is used that needs 3.3V from the bus as power the customer must supply this voltage by itself.*

---

## PC/104 Plus Bus Connector

Pin	A	B	C	D
1	GND	Reserved	+5 Volt	AD00
2	VI/O	AD02	AD01	+5 Volt
3	AD05	GND	AD04	AD03
4	C/BE0	AD07	GND	AD06
5	GND	AD09	AD08	GND
6	AD11	VI/O	AD10	M66EN
7	AD14	AD13	GND	AD12
8	n.c.	C/BE1	AD15	n.c.
9	SERR	GND	SB0	PAR
10	GND	PERR	n.c.	SDONE
11	STOP	n.c.	LOCK	GND
12	n.c.	TRDY	GND	DEVSEL
13	FRAME	GND	IRDY	n.c.
14	GND	AD16	n.c.	C/BE2
15	AD18	n.c.	AD17	GND
16	AD21	AD20	GND	AD19
17	n.c.	AD23	AD22	n.c.
18	IDSEL0	GND	IDSEL1	IDSEL2
19	AD24	C/BE3	VI/O	IDSEL3
20	GND	AD26	AD25	GND
21	AD29	+5 Volt	AD28	AD27
22	+5 Volt	AD30	GND	AD31
23	REQ0	GND	REQ1	VI/O
24	GND	REQ2	+5 Volt	GNT0
25	GNT1	VI/O	GNT2	GND
26	+5 Volt	CLK0	GND	CKL1
27	CLK2	+5 Volt	CLK3	GND
28	GND	INTD	+5 Volt	RST
29	+12 Volt	INTA	INTB	INTC
30	-12 Volt	REQ3	GNT3	GND

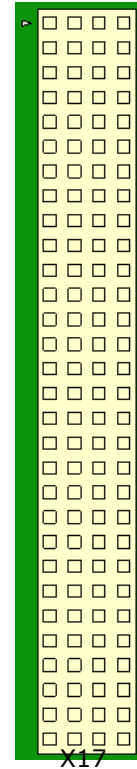

**Note:** All VI/O pins are connected to +3,3 V at default.  
The voltages +5 V, +12 V and -12 V are not generated by the onboard power-supply but they are routed from the Power Supply Connector.  
The maximum current is limited depending on voltage:  
+12 V < 1 A; -12 V < 0,3 A; +5 V < 8 A  
One pin can be used for 1 A at maximum.



### 3.19 BIOS Recovery

Onboard there is a soldered SPI bios connected to an interface of the Super I/O IT8712.

Next to the PC104 header is a connector to plug in a recovery bios on the LPC bus.

If the system should boot from a connected FWH, the pin 6 "BIOS\_DISABLE#" have to push to ground.

The mounted SPI BIOS will be disabled for booting activities and can be reprogrammed with a tool running in DOS.

To program the SPI flash the FWH can be disconnected after the operation system is loaded successfully.

Connector type: Hirose DF13 10 pin header 1.25 mm

Matching connector: Hirose DF13-10S-1.25C, part number 536-0009-6 00

Pin	Signal
1	+3V3 <sup>°</sup>
2	LAD0
3	LAD1
4	LAD2
5	LAD4
6	BIOS_DISABLE#
7	LFRAME#
8	PCI_RST#
9	CLK_33_FWH_R
10	GND

---

<sup>°</sup> 0.3 A is the maximum current for that pin

## 4 Using the Module

### 4.1 Watchdog

A watchdog timer is integrated on-board and managed with the SMC LEMT functionality. There are different possibilities for its activation. More details can be found in the next chapter where a detailed description of the SMC can be found.

A watchdog event is triggered by internal circuit of the ITE8712 Super I/O. It is possible to program the trigger duration, see chapter "Watchdog" for an example.

### 4.2 LEMT functions

The onboard Microcontroller implements power sequencing and LEMT (LIPPERT Enhanced Management Technology) functionality. The microcontroller communicates via the System Management Bus with the CPU/Chipset. The following functions are implemented:

- Total operating hours counter  
Counts the number of hours the module has been run in minutes.
- On-time minutes counter  
Counts the seconds since last system start.
- Power cycles counter
- Watchdog Timer  
Set / Reset / Disable Watchdog Timer.
- System Restart Cause  
Power loss / Watchdog / External Reset.
- Flash area  
1kB Flash area for customer data
- Protected Flash area  
128 Bytes for Keys, ID's, etc. can stored in a write- and clear-protect able area.
- Board Identify  
Vendor / Board / Serial number

LEMT Tools are available for Windows and Linux, LEMT functionality can also be used in applications. Please ask our support for the LEMT software manual and technical manual regarding more details on functionality and how to use it.

## 4.3 BIOS

The Cool SpaceRunner-LX800 is delivered with an Insyde Technology XpressROM BIOS. The default settings guarantee a "ready to run" system, even without a BIOS setup backup battery.

All setup changes of the BIOS are stored in the CMOS RAM. A copy of the CMOS RAM, excluding date and time, is stored in the flash memory. This means that even if the backup battery runs out of power, the BIOS settings are not lost. Only date and time will be reset to their default value.

The soldered battery will keep that information over 2 years without any activation of the board. That depends on the use of the board. When power is up, the battery does not lose capacity.

### *Battery Jumper (Default OFF)*

With the Jumper "Battery", see chapter 2.2, the battery can be disconnected from the system. Because of the flash storage in the BIOS the settings will keep their information after. Except the Real Time Clock will not be up to date.

If the board should be stored for longer times, this is the best solution to save the capacity. The battery loses 1% of its capacity over self-discharge per year without the jumper.

The BIOS revision can be easily updated on-board with software under DOS.

### *Configuring the XpressROM BIOS*

Pressing <F1> on power up starts the BIOS setup utility.

```
Insyde Technology XpressROM Setup
Version: SpaceRunner-LX SRLX0010.BIN      (C)LiPPERT Built: 05/11/2009 15:06:31
----- Main Menu -----
A. Time 10:59:40
B. Date 11/02/2009

C. System Clock/PLL                      D. IDE and Floppy Drives
W. Power Management                     R. Serial and Parallel Ports
M. Miscellaneous                         U. Video and Flat Panel
I. ISA I/O and Memory                   P. PCI Bus
O. Boot Order                           T. Thermal and Watchdog

L. Load Defaults

S. Save Values Without Exit
Q. Exit Without Save
X. Save Values and Exit

Set the current time in the RTC
```

On the screen there are three separated parts:

#### TOP

The part shows information about the current BIOS version. Among it is the name of the associated bin-file. On the right side is the build date shown.

#### MIDDLE

Here are the various menus listed.

## BOTTOM

A short help text about the selected menu is shown.

### Field Selection

To move between fields in Setup, use the keys listed below:

Key	Function
à, ß, â, á	Move between fields
+, -	Selects next/previous values in fields
Enter	Go to the submenu for the field
Esc	To previous field then to exit menu

In order to save your settings, select **Save values and Exit** and confirm with Y.  
Should you want to discard everything, select **Exit Without Save**.

When troubleshooting a system, it is highly recommend to first restoring the BIOS's factory settings before any debugging is done. This is achieved with **Load Defaults** in the main setup menu. If you cannot reach the BIOS setup, because of bad system configuration, reset the board five times for loading default values.

The *Drive Configuration* menu allows configuring connected EIDE devices.

Here you can turn off the primary (and only) ATA controller, disabling the on-board SSD device and IDE connector, maybe in favor of external hardware. Independently, you can disable all IDE drive support (INT 13) in the BIOS, including the capability to boot from IDE. You can also switch the on-board SSD from primary Master to Slave device.

To work around potential incompatibilities it is possible to disable DMA or force specific transfer modes. Note however that as soon as the OS has loaded its native, BIOS-independent ATA driver it will probably override these restrictions.

If “80-Conductor Cable Sense” is set to the default “GPIO 05”, the board will recognize modern 80-wire IDE cables automatically and allow faster transfer rates if one is detected. Changing this option allows overriding the detection if necessary.

Specifically, if no cable is attached, the missing 80-wire signal will force the chipset to assume 40-wire cabling. This will limit the on-board SSD to lower UDMA2 speed. **Therefore, if you haven’t anything connected to the on-board IDE connector, but are only using the SSD, set “80-Conductor Cable Sense” to “Force 80 conductor cable” to gain maximum performance.** Don’t do this if you are planning to connect a device via an old 40-wire IDE cable.

*As SSD standalone will probably be the most common case, the “Force 80” setting has been made the default with BIOS SRLX0013 (not pictured here). To use an old 40-wire cable it has to be manually changed back to “Auto” (previously “GPIO 05” but renamed to be more self-explanatory).*

```

Insyde Technology XpressROM Setup
Version: SpaceRunner-LX SRLX0010.BIN      (c)LiPPERT Built: 05/11/2009 15:06:31
----- Drive Configuration -----

Hard Drive Configuration
Primary ATA Controller: Enabled
On-board SSD Mode:      Master
IDE BIOS Support:      Enabled
  Map Slave HDD First:  Disabled
  80-Conductor Cable Sense: GPIO 05
  DMA/UDMA BIOS Support: Enabled
  Force Mode for Drive 1: Auto
  Force Mode for Drive 2: Auto

Floppy BIOS Support: Disabled
  Force USB Floppy to Drive A: Enabled

CD-ROM Boot BIOS Support: Enabled

Enable/Disable ATA PCI header & legacy ATA descriptors
  
```

Hard Drive Setting	Options
80-Conductor Cable Sense	GPIO 05, NONE, Force 40, Force 80
Drive Modes	Auto, PIO0, PIO1, PIO2, PIO3, PIO4, MDMA0, MDMA1, MDMA2, UDMA0, UDMA1, UDMA2, UDMA3, UDMA4

The *Serial and Parallel Device Configurations* menu allows configuring COM1, COM2 and LPT. COM-Ports can be switched between RS232 and RS485. It is possible to change the resource and interrupts of all ports.

```

Insyde Technology XpressROM Setup
Version: SpaceRunner-LX SRLX0010.BIN (c)LiPPERT Built: 05/11/2009 15:06:31
Serial and Parallel Port Configuration

Serial Port 1: 0x3F8, IRQ 4
Mode: RS232

Serial Port 2: 0x2F8, IRQ 3
Mode: RS232

Parallel Port: 0x378
Mode: Standard (SPP)
IRQ: IRQ 7
DMA: Channel 1

Configure the 1st LPC UART

```

Hard Drive Setting	Options
Serial Port 1/2	Disabled, 0x3f8 IRQ 4, 0x2f8 IRQ 3, 0x3e8 IRQ4, 0x2e8 IRQ3
Serial Mode	RS232, RS485
Parallel Port	Disabled, 0x378, 0x278, 0x3BC
Parallel Mode	Compatible, PS/2 Bi-directional, EPP 1.7, EPP 1.9, ECP
Parallel IRQ	Disabled, IRQ5, IRQ7, IRQ9, IRQ10, IRQ11
Parallel DMA	Channel 1, Channel 3

The *Graphics Configuration* menu allows setting up different displays and their several functions. Possible options are mentioned in chapter "LVDS Configuration" too.

```

Insyde Technology XpressROM Setup
Version: SpaceRunner-LX SRLX0010.BIN      (c)LiPPERT Built: 05/11/2009 15:06:31
----- Graphics Configuration -----

Internal Adaptor Mode: Disabled
Graphics Memory: 24                      Driver Controls Init: Disabled
Output Display: CRT                       DOTPLL Bypass: Disabled

Flat Panel Configuration
Type: LVDS                                HSYNC Polarity: Active low
Resolution: 800x600                       VSYNC Polarity: Active low
Data Bus Type: 5-24 bits, 1 PPC           LP Active Period: Free running
Refresh Rate: 60 Hz                      SHFCLK Active Period: Free running

Mode for internal controller when an external video device is present.

```

The *PCI Configuration* menu contents options about PCI interrupts and USB.

Here the PCI ports can be assigned to an interrupt.

In the USB Settings the different controllers can be selected. Port 4 can be changed to client mode.

```

Insyde Technology XpressROM Setup
Version: SpaceRunner-LX SRLX0010.BIN      (c)LiPPERT Built: 05/11/2009 15:06:31
----- PCI Configuration -----

PCI Interrupt Steering
PCI INTA#: IRQ 10
PCI INTB#: IRQ 11
PCI INTC#: IRQ 5
PCI INTD#: IRQ 15

USB Settings
OHCI (USB 1.1): Enabled
EHCI (USB 2.0): Enabled
UDC (Device): Disabled
UDC (Device): Disabled
Overcurrent Reporting: Disabled
Port 4 Assignment: Host

Additional PCI Headers
GPIO, MFGPT, SMB: Disabled

Enable/Disable INTA# to IRQ steering

```



**Note:** *If you have an external ISA card that needs e.g. IRQ 5, PCI Interrupt steering must be configured in a way that none of the PCI interrupt request is routed to IRQ 5. In this example it would be possible to steer PCI INTC#*

---

to IRQ 10.

---

**System Clock/PLL Configuration** lets you define the CPU and PLL settings.

```
Insyde Technology XpressROM Setup
Version: SpaceRunner-LX SRLX0010.BIN      (c)LiPPERT Built: 05/11/2009 15:06:31
----- System Clock/PLL Configuration -----

Clock Mode
  Clock Determined by: Manual settings

Manual PLL Settings
  CPU Multiplier: 15
  GeodeLink Multiplier: 12

Spread Spectrum: Enabled

33.3MHz * CPU multiplier = CPU speed
```



**Note:** CPU Multipliers above 15 (500Mhz) may seriously damage the CPU!

---

The *Power Management* menu gives control over supported power down modes.

```
Insyde Technology XpressROM Setup
Version: SpaceRunner-LX SRLX0010.BIN (c)LiPPERT Built: 05/11/2009 15:06:31
----- Power Management -----
Legacy BIOS PM at Boot: Disabled

Power Management APIs
APM Available: No
ACPI Available: Yes
S1 Clocks: Off (Least power)
P-State Limit: P1

Clock Gating
CPU Clock Gating: Enabled
Chipset Clock Gating: Enabled

Wake up Events
PS/2 Mouse: None
PS/2 Keyboard: None
Wake up Key: Ctrl+Esc

Power Down Ethernet Chip at Boot: Disabled

BIOS will turn on Legacy PM before booting the OS.
```



**Note:** Some Linux versions may require “acpi=force” as a kernel boot parameter to make use of ACPI.

*Miscellaneous Configuration* controls various other features

```
Insyde Technology XpressROM Setup
Version: SpaceRunner-LX SRLX0010.BIN (c)LiPPERT Built: 05/11/2009 15:06:31
----- Miscellaneous Configuration -----

Splash Screen Configuration
Splash Screen: Enabled
Clear Splash Screen: Enabled
F1 Key Timeout: 2000

Summary Screen Configuration
Summary Screen: Enabled
Summary Screen Timeout: 0

Power Button Configuration
Power Button: ACPI mode

PC Speaker Configuration
AC Beeper: Enabled

Enable/Disable display of splash screen
```

*ISA I/O and Memory Configuration* allows setting the board's ISA memory and I/O map. The *DDMA Configuration* allows activating ISA DMA for channel 0 to 7.

```

Insyde Technology XpressROM Setup
Version: SpaceRunner-LX SRLX0010.BIN      (c)LiPPERT Built: 05/11/2009 15:06:31
----- ISA I/O and Memory Configuration -----

I/O Mapped to ISA
I/O Range 0: Enabled      Size: 128      Base Addr (A15-A0): 0x0100
I/O Range 1: Enabled      Size: 64       Base Addr (A15-A0): 0x0180
I/O Range 2: Enabled      Size: 32       Base Addr (A15-A0): 0x01C0
I/O Range 3: Enabled      Size: 128      Base Addr (A15-A0): 0x0200
I/O Range 4: Enabled      Size: 64       Base Addr (A15-A0): 0x0300
I/O Range 5: Enabled      Size: 32       Base Addr (A15-A0): 0x0340

Memory and DMA Mapped to ISA
Mem Range 0: Enabled      Size: 32K      Base Addr (A23-A0): 0x0CB000
Mem Range 1: Enabled      Size: 64K      Base Addr (A23-A0): 0x0D0000
Mem Range 2: Disabled     Size: 16K      Base Addr (A23-A0): 0x000000
Mem Range 3: Disabled     Size: 16K      Base Addr (A23-A0): 0x000000

DMA Channel 0: Enabled
DMA Channel 1: Disabled   DMA Channel 5: Enabled
DMA Channel 2: Disabled   DMA Channel 6: Enabled
DMA Channel 3: Enabled    DMA Channel 7: Enabled

Enable/Disable mapping selected I/O addresses to ISA

```

By default the following I/O and Memory Ranges are mapped to ISA and NOT accessible for other devices any more:

- I/O: Range-0: 100h-17Fh
- Range-1: 17Fh-1BFh
- Range-2: 1C0h-1DFh
- Range-3: 200h-27Fh
- Range-4: 300h-33Fh
- Range-5: 340h-35Fh

- Memory: Range-0: C8000h-CFFFFh
- Range-1: D0000h-DFFFFh

If a PCI device (e.g. on an external adapter) needs some of these ranges, the space has to be freed, because the system is NOT Plug and Play!

Otherwise, if an external ISA card needs additional I/O or Memory space, the above ranges need to be reconfigured.



**Note:** *You need to know exactly the resources that are needed by external cards in order to setup the BIOS correctly! Otherwise it may be that some cards do not work properly!*

The **Boot Order** menu specifies the order in which the BIOS tries the various mass memory devices for a bootable operating system. Boot over LAN is also supported.

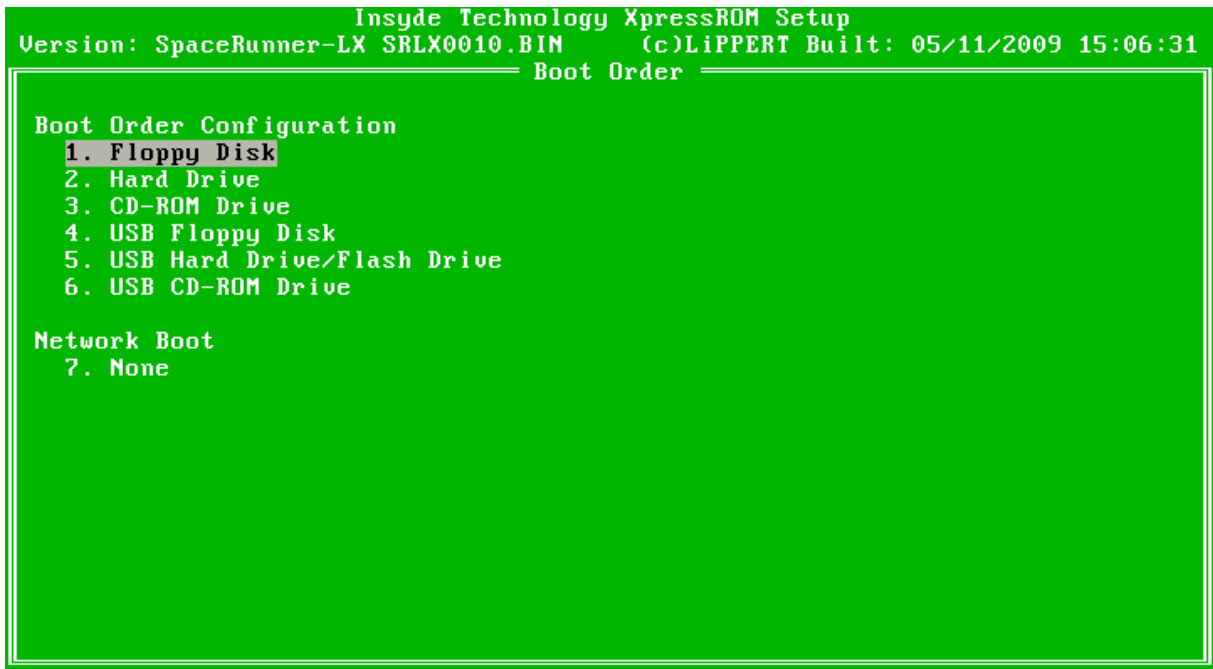

### **Trouble Shooting BIOS Settings**

It may happen that the BIOS is configured that the Cool SpaceRunner-LX800 does not start at all. To repair this, the default values of the BIOS can be automatically loaded at boot time. To load these, the power must be switched on and off again within 2 seconds. This sequence must be repeated 5 times, and then the default values get loaded by the BIOS.

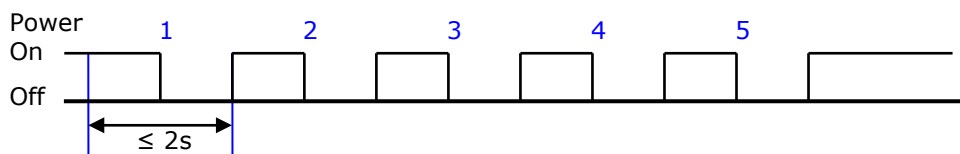

Pressing the Reset-Button five times while the system is booting achieves the same result.

If there is a power down during an upgrade of the BIOS or if a wrong software version has been erroneously flashed, there is the possibility to use a Recovery BIOS.

Next to the PC104 header is a connector to plug in a Recovery BIOS on the LPC bus. The pin assignment can be found at chapter 3.19. If such a recovery BIOS is connected and thus a firmware hub present, this recovery BIOS will be used to boot the computer instead of the SPI BIOS.

The SPI BIOS is then disabled and can be reprogrammed with a Linux/DOS-based tool provided by Lippert..

## 4.4 Drivers

Software drivers for Ethernet, AES and graphics adapter are available for the Cool SpaceRunner-LX800.

These drivers can be downloaded from LiPPERT's website <http://www.lippertembedded.com>.

Follow the installation instructions that come with the drivers.

## 4.5 Programming Examples

The following programming examples are made for a Linux operation system. If other operation systems are used some header files could be unnecessary or they can have different names.

The "iopl()" function is a Linux specific one, in Windows XP a tool called "porttalk" can be used instead.

Be careful with the interpretation of the "outb" order in our examples:

Linux: "outb(value, address)"

DOS, Windows: "outb(address, value)"

The following example is meant to be compiled using gcc under Linux.

### ***LIVE-LED***

The Live-LED can be programmed by users. The cathode of the mounted LED is connected to a GPIO pin of the Super I/O. If the input has ground potential the LED is on.

The Live-LED (red) can be controlled with bit 0 of I/O port 1220h (Super I/O GP10). The BIOS signals with it that the POST is in progress. After that, the LED may be freely used by any application program.

The following Linux program changes the state of the Live-LED.

```
#include <stdio.h>
#include <sys/io.h>

#define PORT 0x1220
#define MASK 0x01

int main()
{
    unsigned char data;
    if (iopl(3)) { //get port access permissions (must be root)
        perror("iopl"); return 1;
    }

    data = inb(PORT); //read GPIOs
    if (data & MASK) { //isolate LED bit (inverse logic!)
        printf("Live LED was off, switching it on.\n");
        outb(data & ~MASK, PORT);
    } else {
        printf("Live LED was on, switching it off.\n");
        outb(data | MASK, PORT);
    }

    iopl(0);
    return 0;
}
```

## Watchdog

Since the Watchdog is disabled in delivery status, it must be set up for proper use.

The Watchdog is an internal feature of the ITE8712 Super I/O. If the Watchdog is activated and the timer is not set back within a programmed amount of time, the board does a system reset.

The mounted LEMT initialize a hardware reset and turns on the watchdog LED.

```
#include <stdio.h>
#include <sys/io.h>
#include <unistd.h>

#define CONF_ADDR 0x2E
#define CONF_DATA 0x2F

int main()
{
    unsigned char i;
    iopl(3);
    outb(0x87, CONF_ADDR); // sets SIO in configuration mode (fixed sequence:
    outb(0x01, CONF_ADDR); // 0x87,0x01,0x55,0x55)
    outb(0x55, CONF_ADDR);
    outb(0x55, CONF_ADDR);
    outb(0x07, CONF_ADDR); // LDN=0x07
    outb(0x07, CONF_DATA);
    outb(0x72, CONF_ADDR); // set time out value to seconds
    outb(inb(CONF_DATA)|0x80, CONF_DATA);
    outb(0x73, CONF_ADDR); //set time out:
    outb(0x03, CONF_DATA); //0x03 -> 3 seconds
    printf("Watchdog enabled. Press CTRL+C within 5 seconds to stop disarming.\n");
    for(i=0; i<5; i++)
    {
        outb(0x73, CONF_ADDR); //reset time out
        outb(0x03, CONF_DATA);
        printf(".");
        fflush(stdout);
        sleep(1);
    }
    outb(0x73, CONF_ADDR);
    outb(0x00, CONF_DATA); //deactivate watchdog
    printf("\nWatchdog disabled\n");
    iopl(0);
    return 0;
}
```

## Reading Temperatures

There are temperature sensors available that allow measurement of the CPU's chip temperature as well as the board's ambient temperature. These are shown in the BIOS setup screens, see above.

```
#include <stdio.h>
#include <unistd.h>
#include <sys/io.h> // needed for inb/outb

#define EC_INDEX 0x295
#define EC_DATA 0x296

int main()
{
    signed char cputemp, ambtemp;

    if (iop(3)) { // Linux-specific, e.g. DOS doesn't need this
        printf("Failed to get I/O access permissions.\n");
        printf("You must be root to run this.\n");
        return 1;
    }

    printf("Press CTRL+C to cancel!\n");
    printf("CPU AMBIENT\n");
    while (1) {

        outb(0x29, EC_INDEX); //read out CPU temp
        cputemp = inb(EC_DATA);
        outb(0x2A, EC_INDEX); //read out ambient temp
        ambtemp = inb(EC_DATA);
        printf("%3d %3d\n", cputemp, ambtemp);

        fflush(stdout);
        sleep(1);
    }

    //return 0;
}
```

## Reading Voltages

The +12/-12V supplies are not used by any on board components, but only forwarded to the PC/104+ and backlight connectors. Still, the voltages on these lines can be monitored in the BIOS Setup (see above) or by an application, as shown here.

```
#include <stdio.h>
#include <sys/io.h> // needed for inb/outb

#define EC_INDEX 0x295
#define EC_DATA 0x296

int main()
{
    signed int p12V, n12V;

    if (!iop(3)) { // Linux-specific, e.g. DOS doesn't need this
        printf("Failed to get I/O access permissions.\n");
        printf("You must be root to run this.\n");
        return 1;
    }

    outb(0x24, EC_INDEX); // read +12 V voltage
    p12V = ((unsigned char)inb(EC_DATA)) * 64; //mV
    printf("+12 V voltage: %+5.1f V\n", p12V/1000.0);

    outb(0x25, EC_INDEX); // read -12 V voltage
    n12V = ((unsigned char)inb(EC_DATA)) * 80 - 16384; //mV
    printf("-12 V voltage: %+5.1f V\n", n12V/1000.0);

    return 0;
}
```

## 5 Address Maps

This section describes the layout of the CPU memory and I/O address spaces.



**Note** Depending on enabled or disabled functions in the BIOS, other or more resources may be used

### 5.1 Memory Address Map

Address range (dec)	Address range (hex)	Size	Description
1024K - 16384K	100000 - FFFFFFFF	15360K	Extended memory
896K - 1024K	E0000 - FFFFFF	128K	System BIOS
800K - 896K	C8000 - DFFFFF	96K	Mapped to ISA (default)
768K - 800K	C0000 - C7FFF	32K	Graphics BIOS
736K - 768K	B8000 - BFFFF	32K	Color text memory
704K - 736K	B0000 - B7FFF	32K	Monochrome text memory
640K - 704K	A0000 - AFFFF	64K	Graphics memory
639K - 640K	9FC00 - 9FFFF	1K	EBDA
0K - 639K	0 - 9FBFF	639K	Conventional memory

## 5.2 I/O Address Map

The system chipset implements a number of registers in I/O address space. These registers occupy the following map in the I/O space:

Address range (hex)	Description
0000 - 000F	DMA controller
0020 - 0021	Programmable interrupt controller
002E - 002F	Super I/O
0040 - 0043	System timer
0048 - 004B	System timer
0060 - 0060	Keyboard
0061 - 0061	System speaker
0064 - 0064	Keyboard
0070 - 0073	System CMOS / Real-time clock
0080 - 008F	DMA controller
0092 - 0092	System
00A0 - 00A1	Programmable interrupt controller
00C0 - 00DF	DMA controller
00F0 - 00FF	Numeric coprocessor
0100 - 017F	*PCI-ISA bridge positive decode range 1 (default)
0180 - 01BF	*PCI-ISA bridge positive decode range 2 (default)
01C0 - 01DF	*PCI-ISA bridge positive decode range 3 (default)
01F0 - 01FF	*IDE controller
0200 - 027F	*PCI-ISA bridge positive decode range 4 (default)
0279 - 0279	(ISA-PnP data port)
0290 - 0297	Environment controller
0298 - 029B	PME direct access
02F8 - 02FF	*Serial port 2
0300 - 033F	*PCI-ISA bridge positive decode range 5 (default)
0340 - 035F	*PCI-ISA bridge positive decode range 6 (default)
0378 - 037F	*Parallel port
03B0 - 03BA	VGA
03C0 - 03DF	VGA
03F0 - 03F7	(Floppy controller)
03F8 - 03FF	*Serial port 1
0480 - 048F	DMA controller
04D0 - 04D1	Programmable interrupt controller
0A79 - 0A79	(ISA-PnP data port)
0CF8 - 0CFF	PCI config space
1220 - 1227	Simple-I/O
1228 - 122F	SPI flash
1390 - 13FF	*DDMA controller
AC1C - AC1F	VSA

\* Item can be moved or disabled in BIOS Setup

### 5.3 Interrupts

IRQ	System Resource
0	Timer
1	Keyboard
2	(Secondary interrupt controller)
3	Serial port 2
4	Serial port 1
5	PCI INTC#
6	(not used)
7	Parallel port
8	Real-time clock
9	ACPI (Environment controller)
10	PCI INTA# (Graphics, ethernet, AES)
11	PCI INTB# (Misc. CS5536 devices)
12	PS/2 mouse
13	Numeric coprocessor
14	Primary IDE channel
15	PCI INTD# (USB)



**Note** Depending on the BIOS settings, it is possible to reserve several IRQs for the PC/104 or PC/104 plus bus

### 5.4 DMA Channels

DMA	Data width	System Resource
0	8 bits	Available
1	8 bits	Parallel port (ECP mode)
2	8 bits	Available
3	8 bits	Available
4		Reserved, Cascade Channel
5	16 bits	Available
6	16 bits	Available
7	16 bits	Available

## 5.5 PC/104 Bus Address Space

The PC/104 bus address space mapping can be changed in the BIOS setup. The table shows the factory default values. None of these ranges is used by any on-board devices so they all may be changed at will.

Range	Start Address	End Address	Size	Description
I/O 0	100	17F	128 bytes	IT8712 Positive Decode I/O Range 1
I/O 1	180	1BF	64 bytes	IT8712 Positive Decode I/O Range 2
I/O 2	1C0	1DF	32 bytes	IT8712 Positive Decode I/O Range 3
I/O 3	200	27F	128 bytes	IT8712 Positive Decode I/O Range 4
I/O 4	300	33F	64 bytes	IT8712 Positive Decode I/O Range 5
I/O 5	340	35F	32 bytes	IT8888 Positive Decode I/O Range 6
Mem 0	C8000	CFFFF	32 Kbytes	Memory mapped to ISA
Mem 1	D0000	DFFFF	64 Kbytes	Memory mapped to ISA
Mem 2			-	Disabled
Mem 3			-	Disabled

## Appendix A, Contact Information

### *Headquarters*

LiPPERT Embedded Computers GmbH  
Hans-Thoma-Straße 11  
68163 Mannheim  
Germany

Phone	+49 621 43214-0
Fax	+49 621 4321430
E-mail	sales@lippertembedded.com support@lippertembedded.com
Website	www.lippertembedded.com

### *US Office*

LiPPERT Embedded Computers, Inc.  
2220 Northmont Parkway Suite 250  
Duluth, GA 30096  
USA

Phone	+1 (770) 295 0031
Fax	+1 (678) 417 6273
E-mail	ussales@lippertembedded.com support@lippertembedded.com
Website	www.lippertembedded.com

## Appendix B, Additional Information

### B.1 Additional Reading

AMD Geode™ LX Processors Data Book

AMD Geode™ CS5536 Companion Device Data Book

Datasheet LPC interface ITE IT8712F, available at <http://www.ite.com.tw>

### B.2 PC/104 and PC/104-Plus Specifications

A copy of the latest PC/104 and PC104-Plus specifications can be obtained from the PC/104 Consortium's website at [www.pc104.org](http://www.pc104.org)

## Appendix C, Getting Help

Should you have technical questions that are not covered by the respective manuals, please contact our support department at [support@lippertembedded.com](mailto:support@lippertembedded.com) .

Please allow one working day for an answer!

Technical manuals as well as other literature for all LiPPERT products can be found in the *Products* section of LiPPERT's website [www.lippertembedded.com](http://www.lippertembedded.com). Simply locate the product in question and follow the link to its manual.

### Returning Products for Repair

To return a product to LiPPERT for repair, you need to get a Return Material Authorization (RMA) number first. Please print the RMA Request Form from <http://www.lippertembedded.com/service/repairs.html> fill in the blanks and fax it to +49 621 4321430. We'll return it to you with the RMA number.

**Deliveries without a valid RMA number are returned to sender at his own cost!**

LiPPERT has a written Warranty and Repair Policy, which can be retrieved from <http://www.lippertembedded.com/service/warranty.html>

It describes how defective products are handled and what the related costs are. Please read this document carefully before returning a product.

## Appendix D, Revision History

Filename	Date	Edited by	Change
TME-104P-CSR_LX800-R0V1.doc	2008-05-09	CS	Draft
TME-104P-CSR_LX800-R0V2.doc	2008-05-28	CS	Block diagram, wrong USB connector removed
TME-104P-CSR_LX800-R0V3.doc	2008-06-05	JR	RS485, ISA-Bus, ACPI with Linux, Live-LED, minor changes and typos
TME-104P-CSR_LX800-R0V4.doc	2008-07-10	CS	Solid State Disk: SST instead of Intel
TME-104P-CSR_LX800-R0V5.doc	2008-09-01	CS	Changed all BIOS hardcopies
TME-104P-CSR_LX800-R0V6.doc	2008-09-09	PK	MTBF figures added
TME-104P-CSR_LX800-R0V7.doc	2008-09-15	CS	Refreshed chapter 3.13 from SMC to LEMT content
TME-104P-CSR_LX800-R1V0.doc	2008-10-30	PK	Released
TME-104P-CSR_LX800-R1V1.doc	2008-12-01	CS	2.3 LIVE LED description 4.3 Added program example for Live-LED 5.7 correction of signals
TME-104P-CSR_LX800-R1V2.doc	2008-12-15	CS	4.1 New diagram of BIOS trouble shooting BIOS screen shots updated
TME-104P-CSR-LX800-R1V3.doc	2008-12-22	MF	Minor corrections
TME-104P-CSR-LX800-R1V4.doc	2009-01-08	CS	Ch. 1.4 dimensions added Ch. 4.5 program failure corrected
TME-104P-CSR-LX800-R1V5.doc	2009-03-11	CS	Ch. 1.3 footnote added
TME-104P-CSR-LX800-R1V6.doc	2009-04-14 2009-04-27  2009-06-10  2009-07-01	CS JR  CS  JR	Ch. 3.9 USB numbering changed by -1 Ch. 4.3 made program example for Live-LED work Ch. 5 corrections in address maps Ch. 3.8 Reset-In on pin 10 removed Ch. 3.20 Pin C19 is KEY not GND Ch. 4.6 added voltage readout example
TME-104P-CSR-LX800-R1V7.doc	2009-09-29	CS	Ch. 2.1 Top added label to EIDE connector Ch. 2.2 hyperlinks to jumper added Ch. 3.3 LVDS color mapping added article numbers of cable adapters added added links from port overview to chapters added foot prints to power supply pins Ch. 1.2 Article number corrected
TME-104P-CSR-LX800-R1V8.doc	2009-11-02         2009-11-26	CS         JR	Ch. 1.4 metrics added Ch. 3.10 max. baud rates added Ch. 3.15 External Battery added Ch. 3.17 BIOS Recovery added Ch. 4.3 BIOS screen shots updated Ch. 4.4 structure changed General: added RefDes to all connectors Ch. 5.2 SRLX0012.BIN moved SPI and DDMA I/O ranges
TME-104P-CSR-LX800-R1V9.doc	2010-03-03 2010-07-07	CS  JR	Ch. 3.16 Added reference to IRQ, DRQ and DACK signals Ch. 2.3 Replaced position of MAIN and PM LED Ch. 4.3 Clarified "Drive Configuration"
TME-104P-CSR-LX800-R1V10.doc	2010-07-29	MS	Matching parts / connectors added

Filename	Date	Edited by	Change
TME-104-CSR-LX800-R1V11	2011-04-01	MF	Ch.3.15 Internal battery included
TME-104-CSR-LX800-R1V12	2011-07-29	PK	Ordering number for cable set corrected