

Cool LiteRunner-86DX PC/104 CPU Board

Technical Manual

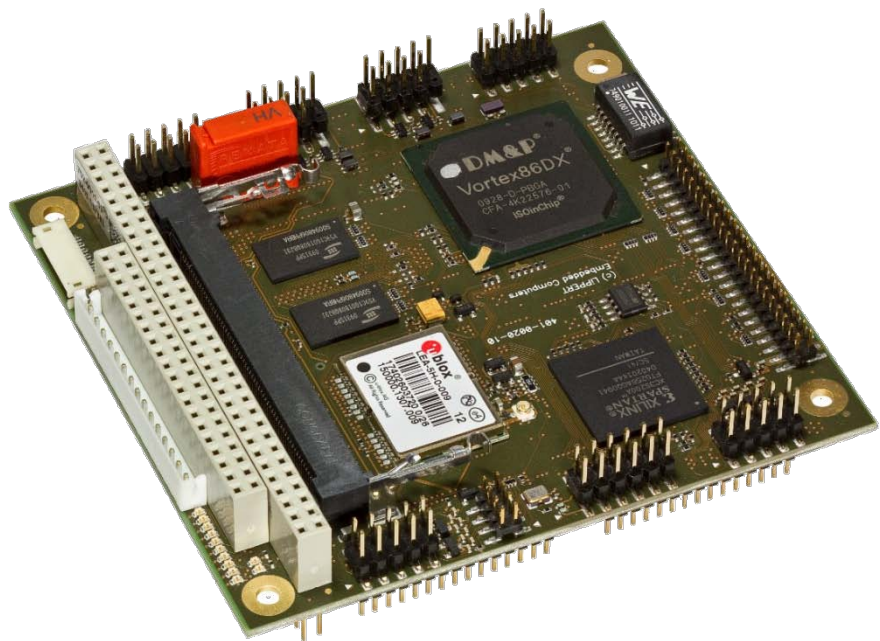

TME-104-CLR-86DX-R1V1
Revision 1.1 / October 11

© LIPPERT Embedded Computers GmbH
Hans-Thoma-Str. 11
D-68163 Mannheim
<http://www.lippertembedded.com/>

Technical Manual Cool LiteRunner-86DX

LiPPERT Document: TME-104-CLR-86DX-R1V1 Revision 1.1

Copyright ©2011 LiPPERT Embedded Computers GmbH, All rights reserved

Trademarks

MS-DOS, Windows, Windows 95, Windows 98, Windows NT and Windows XP are trademarks of Microsoft Corporation. PS/2 is a trademark of International Business Machines, Inc. Intel and Solid State Drive are trademarks of Intel Corporation. Geode is a trademark of Advanced Micro Devices. PC/104 is a registered trademark of PC/104 Consortium. All other trademarks appearing in this document are the property of their respective owners.

Disclaimer

Contents and specifications within this technical manual are subject of change without notice.

LiPPERT Embedded Computers GmbH provides no warranty with regard to this technical manual or any other information contained herein and hereby expressly disclaims any implied warranties of merchantability or fitness for any particular purpose with regard to any of the foregoing. LiPPERT Embedded Computers GmbH assumes no liability for any damages incurred directly or indirectly from any technical or typographical errors or omissions contained herein or for discrepancies between the product and the technical manual. In no event shall LiPPERT Embedded Computers GmbH be liable for any incidental, consequential, special, or exemplary damages, whether based on tort, contract or otherwise, arising out of or in connection with this user's guide or any other information contained herein or the use thereof.

Table of Contents

1	Overview	1
1.1	Acronyms.....	1
1.2	Introduction	2
	Features	2
	Block Diagram.....	3
1.3	Ordering Information	4
	Cool LiteRunner-86DX models	4
	Cable sets and accessories	4
1.4	Specifications.....	5
	Electrical Specifications	5
	Environmental Specifications	5
	MTBF.....	5
1.5	Mechanical	6
	Top	6
	Bottom (vertical mirrored)	7
2	Getting Started	8
2.1	Connector Locations	8
	Top	8
	Bottom	9
2.2	Jumper Locations.....	10
2.3	LED indicators	11
2.4	Hardware Setup.....	12
3	Module Description	13
3.1	Processor + Chipset (SoC: System on Chip).....	13
3.2	MicroSD Slot.....	14
3.3	Ethernet Controller.....	14
	Ethernet Interface	14
3.4	On Board Power Supply	15
	Power Connector	15
3.5	EIDE Port.....	16

EIDE Connector	16
3.6 PS/2 Interface	17
Keyboard and Mouse Connector	17
3.7 USB 2.0 Ports	17
USB 2.0 Connector 0/1	17
USB 2.0 Connector 2/3	18
3.8 Serial Ports.....	18
COM1	19
COM2	19
RS485-Termination Jumpers	19
3.9 Speaker.....	20
3.10 External Power-Button	21
3.11 Reset-In Signal	21
3.12 External Battery	21
3.13 Supervisory	22
3.14 Mini-PCI BUS Interface	23
Mini-PCI Connector (X3)	24
3.15 PC/104 Bus Interface	25
PC/104 Bus Connector	25
3.16 JTAG-CPU (BIOS recovery)	26
3.17 FPGA (Field Programmable Gate Array)	26
3.18 JTAG-FPGA.....	27
3.19 FPGA-I/O Connectors.....	27
Differential signal and “Global Clock” connector 1 (X13).....	27
Differential signal and “Global Clock” connector 2 (X15).....	28
Single ended signal connector 1 (X14)	28
Single ended signal, VCCO and VREF connector 1 (X16).....	29
3.20 BoR – “Bridge of Redundancy” connector	30
3.21 GPS – Global Positioning System.....	32
3.22 SMC Service Connector	32
3.23 Battery Jumper	32

4 Using the Module

33

4.1	Watchdog	33
4.2	LEMT functions.....	33
4.3	BIOS.....	36
	Battery Jumper	36
	Configuring the BIOS.....	36
	Trouble Shooting BIOS Settings	44
4.4	Programming Examples	45
	GPIOs on SUPERVISORY	45
	Watchdog	46
	RS232 / RS485 switching	48
4.5	Drivers	49
5	Address Maps	50
5.1	Memory Address Map	50
5.2	I/O Address Map	51
5.3	Interrupts	52
5.4	DMA Channels.....	53
	Appendix A, Contact Information	A
	Appendix B, Additional Information	B
B.1	Additional Reading.....	B
B.2	PC/104.....	B
	Appendix C, Getting Help	C
	Appendix D, Revision History	D

1 Overview

1.1 Acronyms

AGPI	Advanced Configuration and Power Interface
ATA	Advanced Technology Attachment
BIOS	Basic Input Output System
CD	Compact Disc
CF	Compact Flash
COM	Communication Equipment
CPU	Central Processing Unit
DAC	Digital-to-Analog-Converter
DDR	Double Date Rate
DMA	Direct Memory Access
DOT	Dynamic Overclocking Technology
EIDE	Enhanced Integrated Device Electronics
EMC	Electromagnetic Compatibility
ESPI	External SPI bus of the Vortex86DX
ETH	Ethernet
FIFO	First In First Out
FPGA	Field Programmable Gate Array
FPU	Floating Point Unit
GPIO	General Purpose Input Output
GPS	Global Positioning System
GP-SPI	GPIO based SPI bus
HDD	Hard Disk Drive
I ² C	Inter-Integrated Circuit
IP	Internet Protocol
ISA	Industry Standard Architecture
LED	Light Emitting Diode
LPC	Low Pin Count
MAC	Media Access Control
MMU	Memory Management Unit
PCI	Peripheral Component Interconnect
PE	Potential Earth
PME	Power Management Event
PHY	Physical Interface
PLL	Phase-Locked Loop
PS/2	Personal System/2
PWR	Power
SD	Secure Digital (MicroSD – Micro Secure Digital)
SDHC	SD High Capacity
SMB	System Management Bus
SMC	System Management Controller
SPI	Serial Peripheral Interface
TCP	Transmission Control Protocol
UART	Universal Asynchronous Receiver Transmitter
USB	Universal Serial Bus
UDMA	Ultra-Direct Memory Access
UDP	User Datagram Protocol
VGA	Video Graphics Array
WDOG	Watchdog

1.2 Introduction

The Cool LiteRunner-86DX is a PC/104 board with DMP's Vortex86DX single chip solution and has a very good performance- power- ratio. The board comprises all peripherals needed for an embedded PC on a small 3.775" by 4.050" printed circuit board.

The Cool LiteRunner-86DX integrates a powerful yet efficient DMP Vortex86DX with a Xilinx FPGA and a GPS module to form a complete PC, with all the standard peripherals already onboard. There is no graphic controller and no audio controller integrated.

One fast 100/10BaseT Ethernet port, two RS232/RS422/RS485 serial ports, four USB 2.0 host ports and a USB device port handle the communication with external devices. There are PS/2 connectors for keyboard and mouse as well as an IDE ATA100 adapter allows connection of hard disk or CD drives. Applications that require non-moving storage can use the MicroSD slot or the bootable flash.

System expansion can easily be realized over PC/104, Mini-PCI, SPI, LPC and I²C bus connectors.

The Cool LiteRunner-86DX is powered by a 5V-only supply. Two Cool LiteRunner-86DX boards can run together in a redundancy mode to make security critical applications more secure.

The Cool LiteRunner-86DX runs DOS, Windows XP and Linux operating systems.

The Vortex86DX SoC does not support ACPI so suspend modes S3 and S4 are not available.

Features

CPU + Chipset (single chip solution)

- DMP Vortex86DX (600 / 800 / 1000 MHz)

Extension slots

- 1 x 16-bit PC/104 with full DMA capability
- 1 x Mini PCI Slot

Main Memory

- soldered 256 or 512 MB DDR2 RAM 333 MHz

Interfaces

- 1 x Ethernet 10/100BaseT
- MicroSD slot
- ATA-6 EIDE (Ultra DMA-100)
- PS/2 Keyboard/Mouse
- 4 x USB 2.0 ports
- 2 x RS232 / RS485 / RS422, software selectable
- MISC signals:
 - external power button, I²C bus, speaker, external reset button, hardware monitoring and general purpose signals external battery connector
- Redundancy over cable possible
- Power supply

Onboard devices

- 1x uBlox GPS module (Galileo ready)
- 1x Customer-I/O FPGA (Xilinx)
- 1x bootable 8MB flash
- 1x SMC / LEMT

Other configurations are possible at high volumes.

Block Diagram

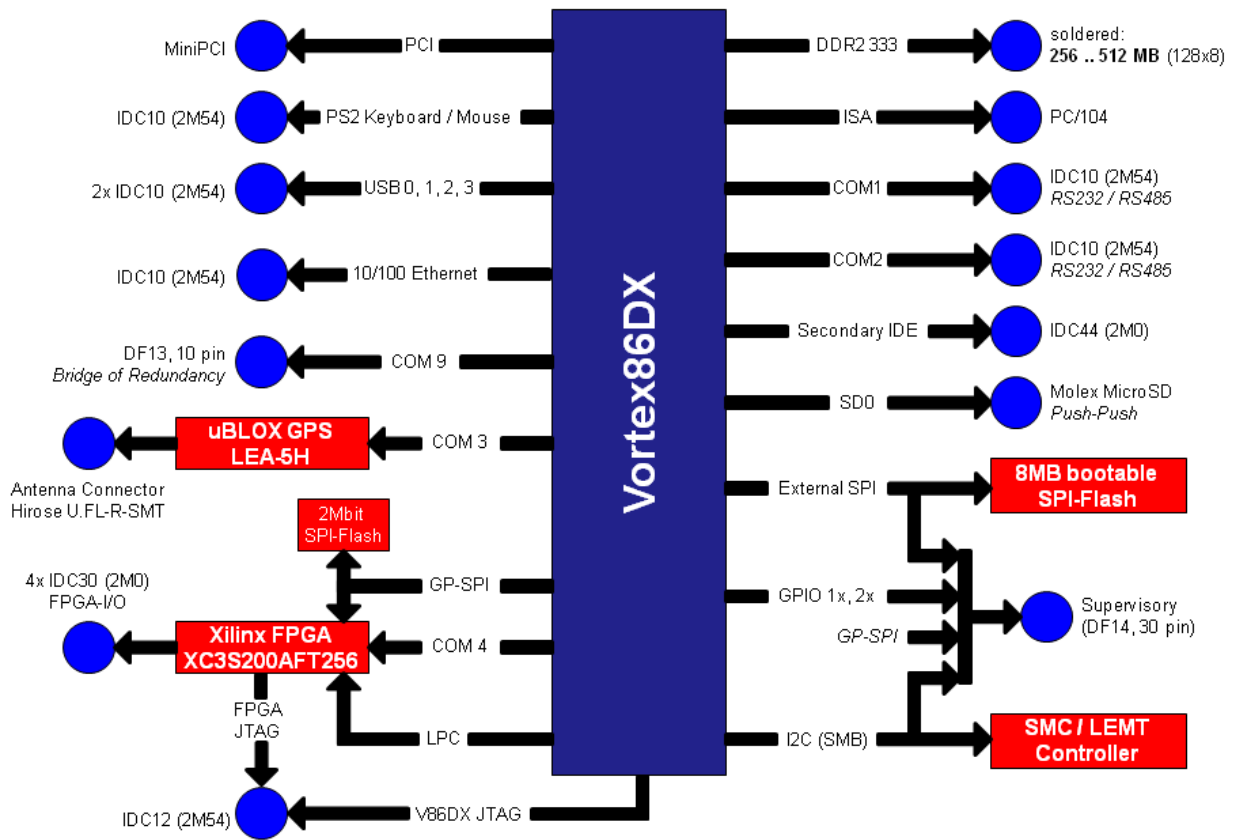

1.3 Ordering Information

Cool LiteRunner-86DX models

Order number	Description
02-0017-00	Cool LiteRunner-86DX with DMP Vortex86DX, 512 MB DDR2 RAM, 4x USB2.0, EIDE, MicroSD socket, 2x COM, PS/2 Keyboard, PS/2 Mouse, 1x Fast Ethernet 100/10BaseT, no GPS, no FPGA, WDOG, RTC, Battery, LEMT, PC/104 bus Operating temp. range: $t = 7 \rightarrow 0^{\circ}\text{C} \dots +60^{\circ}\text{C}$ $t = 8 \rightarrow -20^{\circ}\text{C} \dots +60^{\circ}\text{C}$ $t = 9 \rightarrow -40^{\circ}\text{C} \dots +85^{\circ}\text{C}$
02-0011-00	Cool LiteRunner-86DX with DMP Vortex86DX, 512 MB DDR2 RAM, 4x USB2.0, EIDE, MicroSD socket, 2x COM, PS/2 Keyboard, PS/2 Mouse, 1x Fast Ethernet 100/10BaseT, 1x uBlox GPS, 1x Xilinx FPGA, WDOG, RTC, Battery, LEMT, PC/104 bus Operating temp. range: $t = 7 \rightarrow 0^{\circ}\text{C} \dots +60^{\circ}\text{C}$ $t = 8 \rightarrow -20^{\circ}\text{C} \dots +60^{\circ}\text{C}$ $t = 9 \rightarrow -40^{\circ}\text{C} \dots +85^{\circ}\text{C}$

Other configurations are possible. Please contact sales@lippertembedded.com.

Cable sets and accessories

Order number	Description
763-0020-10	Adapter Cable Set PS/2 keyboard and mouse, Ethernet, 2x USB, COM1, COM2, IDE (44 pin, 2mm), cable adapter 2.5" > 3.5", adapter 3.5" > 2.5"

Mini PCI extension boards

Order number	Description
806-0005-10	Mini-PCI module, 2x Firewire port, w/o cable. Operating temp. range: $-20^{\circ}\text{C} \dots +60^{\circ}\text{C}$
806-0006-10	Mini-PCI module, 2x COM (RS232/422/485), 2 cables. Operating temp. range: $-20^{\circ}\text{C} \dots +60^{\circ}\text{C}$
806-0017-10	Mini-PCI module, 1x VGA Operating temp. range: $-20^{\circ}\text{C} \dots +60^{\circ}\text{C}$

1.4 Specifications

Electrical Specifications

Supply voltage	+5 V DC	Voltage control limits: +5.0 V	Lower limit: 4.2 V no upper limit
		Internal voltages	Rising threshold: 89 ... 95% Falling threshold: 85 ... 91 % of generated voltage, no upper limit
Rise time	< 10 ms		
Supply voltage tolerance	± 5% ¹		
Inrush current	3.2 A		
Supply current (measured with load in Linux)	<p> 102-0011-00 <i>(512MB RAM, GPS, FPGA)</i> </p> <p> 102-0016-00 <i>(256MB RAM, no GPS, no FPGA)</i> </p>	<p>With Mini-PCI VGA : 1.0 ... 1.1 A → ca. 5.0 ... 5.5 W</p> <p>Without Mini-PCI VGA : 0.6 ... 0.7 A → ca. 3.0 ... 3.5 W</p> <p>With Mini-PCI VGA : 0.9 ... 1.0 A → ca. 4.5 ... 5.0 W</p> <p>Without Mini-PCI VGA : 0.5 ... 0.6 A → ca. 2.5 ... 3.0 W</p>	

Environmental Specifications

Operating:

Temperature range	0 ... 60 °C (commercial version) -20 ... 60 °C (industrial version) -40 ... 85 °C (extended version)
Temperature change	Max. 10K / 30 minutes
Humidity (relative)	10 ... 90 % (non-condensing)
Pressure	450 ... 1100 hPa

Non-Operating/Storage/Transport:

Temperature range	-40 ... 85 °C and more t.b.d.
Temperature change	Max. 10K / 30 minutes
Humidity (relative)	5 ... 95 % (non-condensing)
Pressure	450 ... 1100 hPa

MTBF

MTBF at 25°C	290.665 hours
--------------	---------------

¹ Pluggable devices might need power supply with a different tolerance.

1.5 Mechanical

Dimensions (LxW)	95.9 mm x 90.2 mm (including I/O extension)
Height	Max. 14 mm on topside above PCB max. 11 mm on bottom side above PCB
Weight	80 g
Mounting	4 mounting holes



Note: It is strongly recommend using plastic spacers instead of metal spacers to mount the board. With metal spacers, there is a possible danger to create a short circuit with the components located around the mounting holes. This can damage the board!

Top

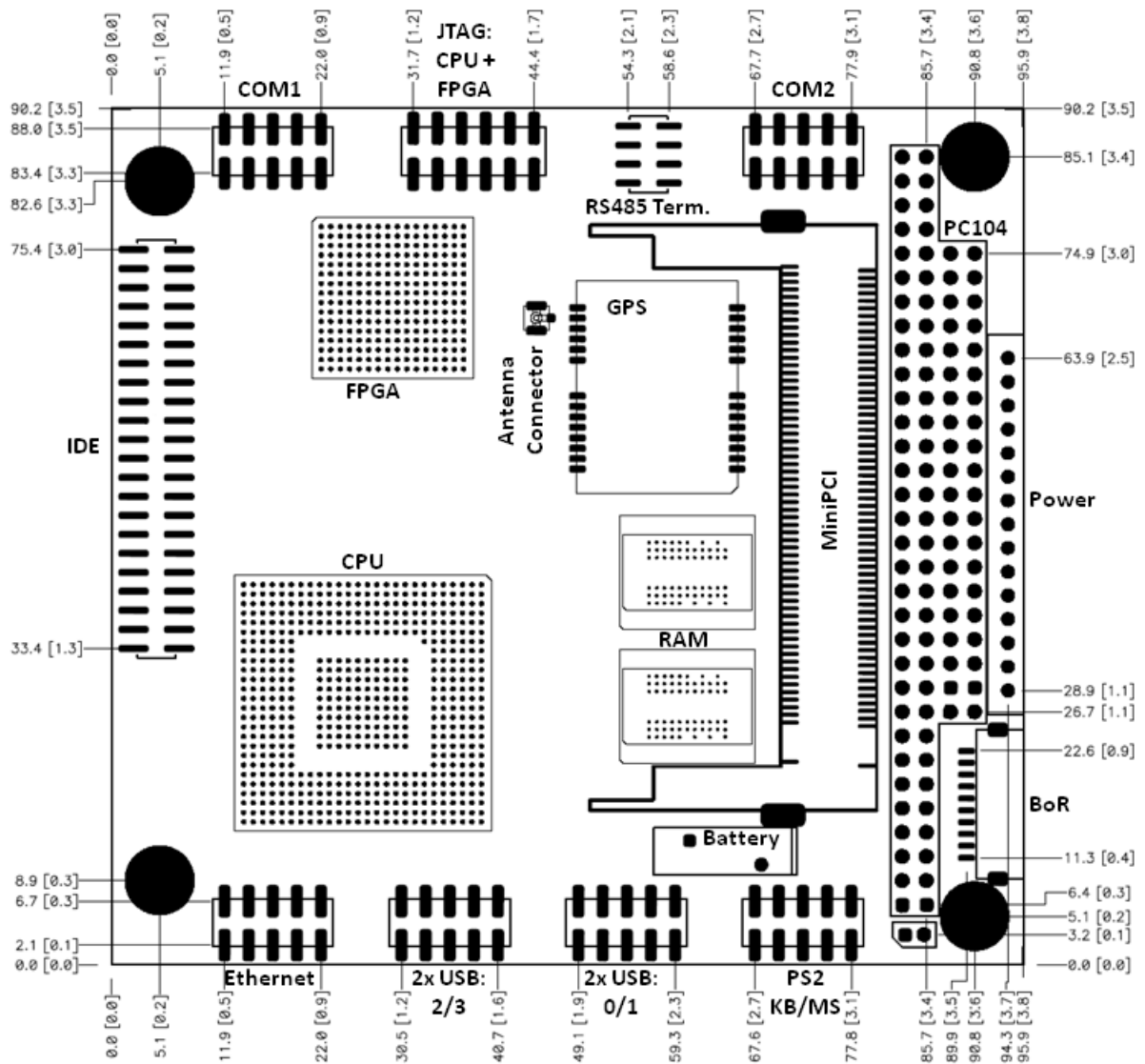

Bottom (vertical mirrored)

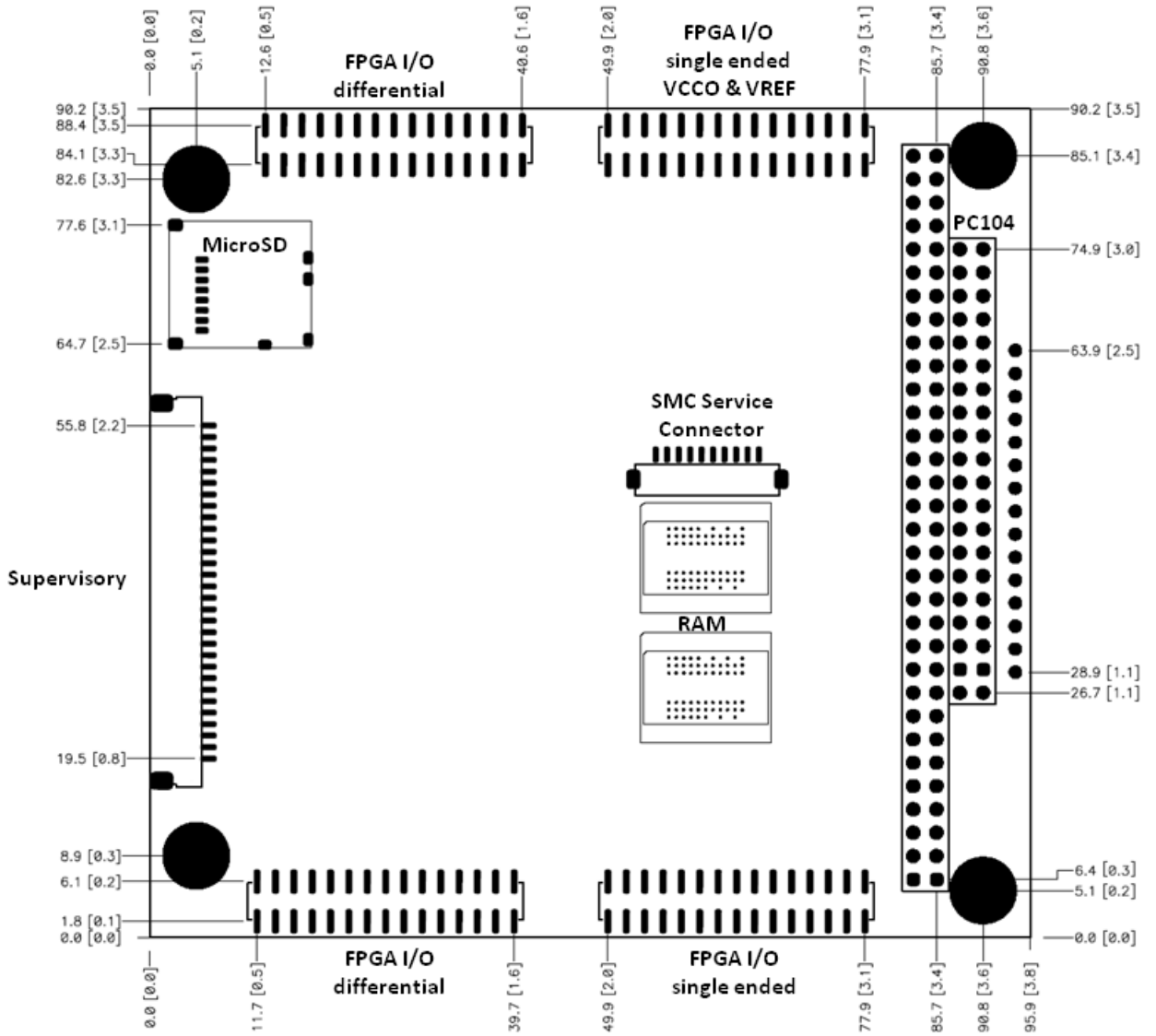

2 Getting Started

2.1 Connector Locations

Top

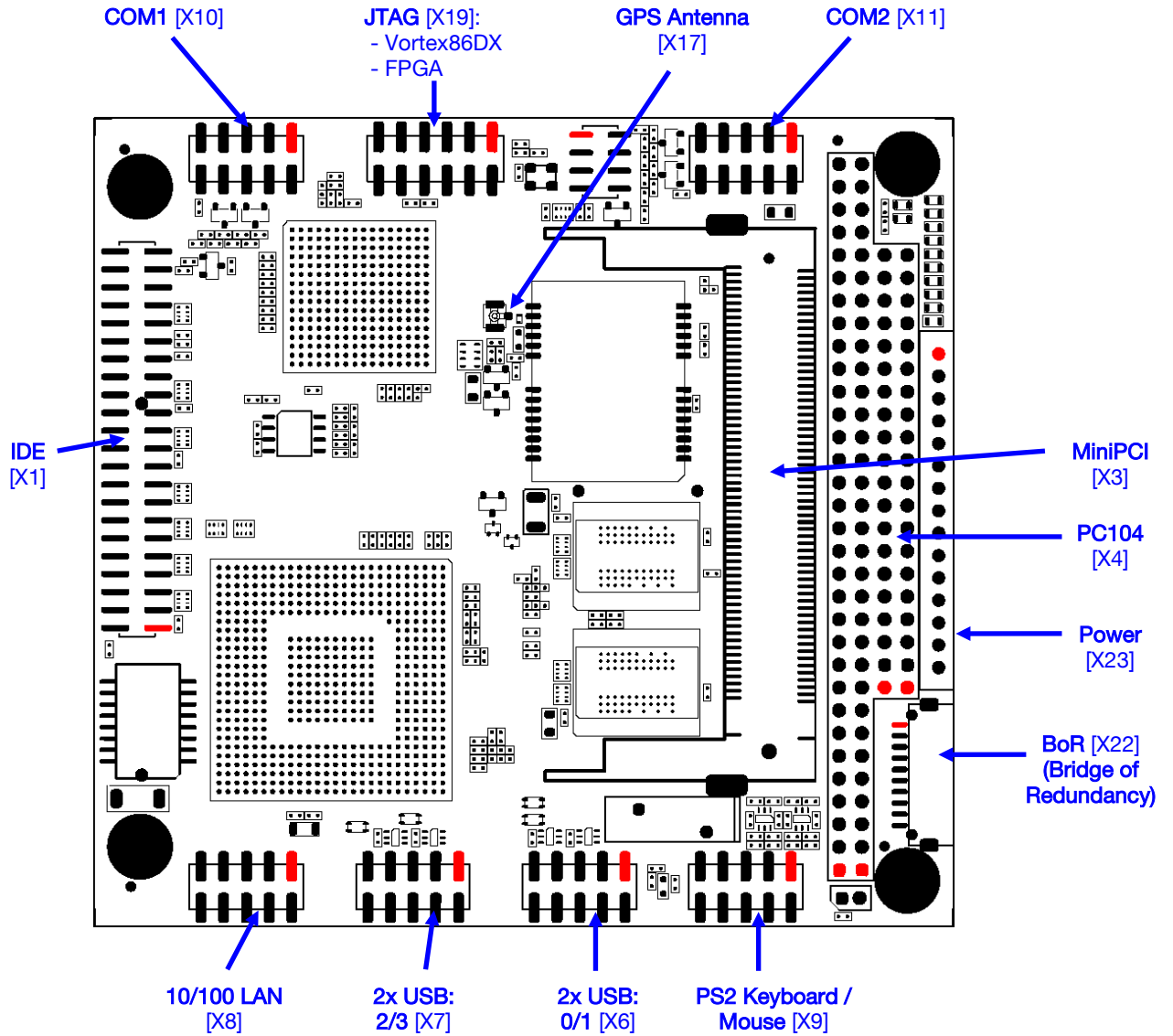

The connectors' pin 1 is marked **RED**

Bottom

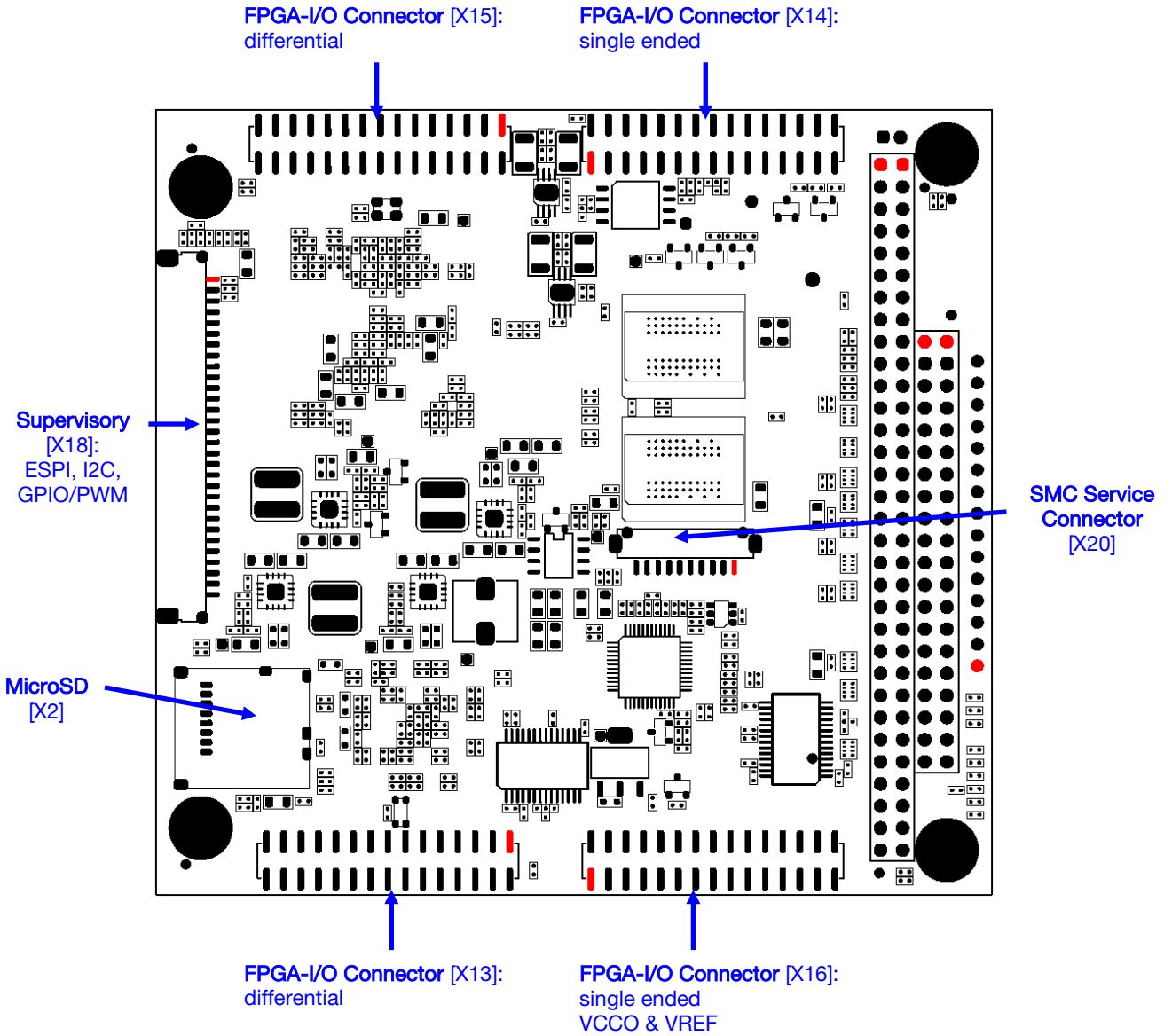

The connectors' pin 1 is marked **RED**

2.2 Jumper Locations

Top

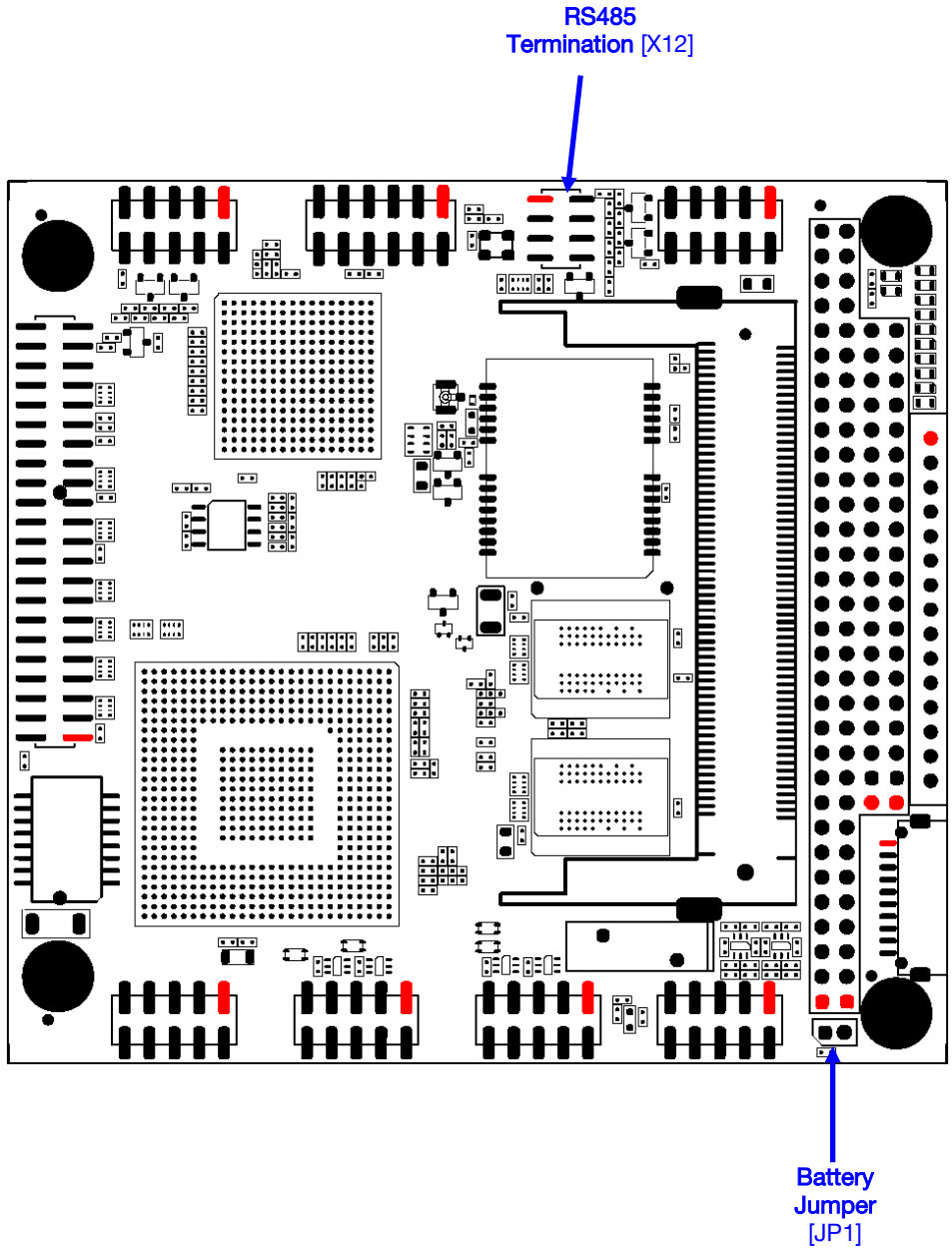

2.3 LED indicators

The onboard LED indicators provide a very comfortable way to check the board's status. The boot success, power status, IDE accesses, Watchdog and Ethernet accesses are all visible.

The LED indicators are located on top of the board, near the PC/104 connector.

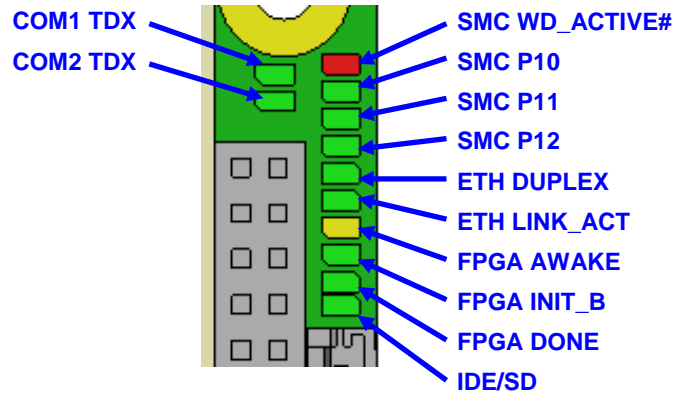

<u>COM1 TXD</u>	Green LED indicates data traffic on COM1.
<u>COM2 TXD</u>	Green LED indicates data traffic on COM2.
<u>WD_ACTIVE#</u>	Red LED lights up whenever the SMC Watchdog was triggered. LED can only be reset by a power off.
<u>SMC P10...P12</u>	Green LEDs show blink codes for debugging.
<u>Eth Duplex</u>	Green LED will light down if Ethernet runs in duplex mode.
<u>Eth Link/Act</u>	Green LED lights up on Ethernet link. It blinks on Ethernet action.
<u>FPGA AWAKE</u>	Yellow LED lights down when FPGA is in Suspend. It lights up if configuration has been realized successfully.
<u>FPGA INIT_B</u>	Green LED lights high up while reading configuration.
<u>FPGA DONE</u>	Green LED lights up when FPGA finished reading configuration.
<u>IDE/SD</u>	Yellow LED indicates data traffic on IDE and MicroSD.

2.4 Hardware Setup



Caution

Be sure to observe the EMC security measures. Make sure you are always at the same potential as the module.



Caution

Never connect or disconnect peripherals like HDD-, PCI- and ISA- devices while the board's power supply is connected and switched on!

Use the cable set and the Mini-PCI-VGA card provided by LIPPERT to connect the Cool LiteRunner-86DX to a VGA monitor. Connect PS/2 or USB keyboard and mouse, respectively. Use the 44-wire cable to connect the harddisk. Make sure that the pins match their counterparts correctly and are not twisted! If you plan to use additional other peripherals, now is the time to connect them, too.

Set the "Jumper Battery" that it has contact with both pins. The location can be found on chapter 2.2.

Connect a 5 volt power supply to the power connector and switch the power on.



Note *In continuous mode there are not more than 1.2 amps necessary, but at power on there are approximately t.b.d. A needed for a short time. That energy should be supplied for this moment.
The value can increase with additions peripherals.*

The display shows the BIOS messages. If you want to change the standard BIOS settings, press the key to enter the BIOS menu. See chapter 4.3 for setup details.

If you need to load the BIOS default values, they can be automatically loaded at boot time. See chapter 4.3 how to do it.

The Cool LiteRunner-86DX boots from CD drive, MicroSD, soldered flash, Compact Flash, USB floppy, USB stick, or harddisk. Provided that any of these is connected and contains a valid operating system image, the display then shows the boot screen of your operating system.

The Cool LiteRunner-86DX does not need any cooling measures, neither at standard environment temperatures from 0 °C ... +60 °C.

3 Module Description

3.1 Processor + Chipset (SoC: System on Chip)

The DMP Vortex86DX SoC delivers a very low power single chip solution, providing x86 power and versatility to embedded products. Its architecture and high level of integration guarantees longer battery life and allows very small designs, while delivering full x86 functionality.

The DMP Vortex86DX SoC consumes a maximum power of 3W max. and 2W typ. at 800 MHz, enabling systems that only need to be passively cooled.

The x86 compatibility allow designers to focus on developing end products that efficiently meet consumer needs without being concerned with software porting or compatibility issues.

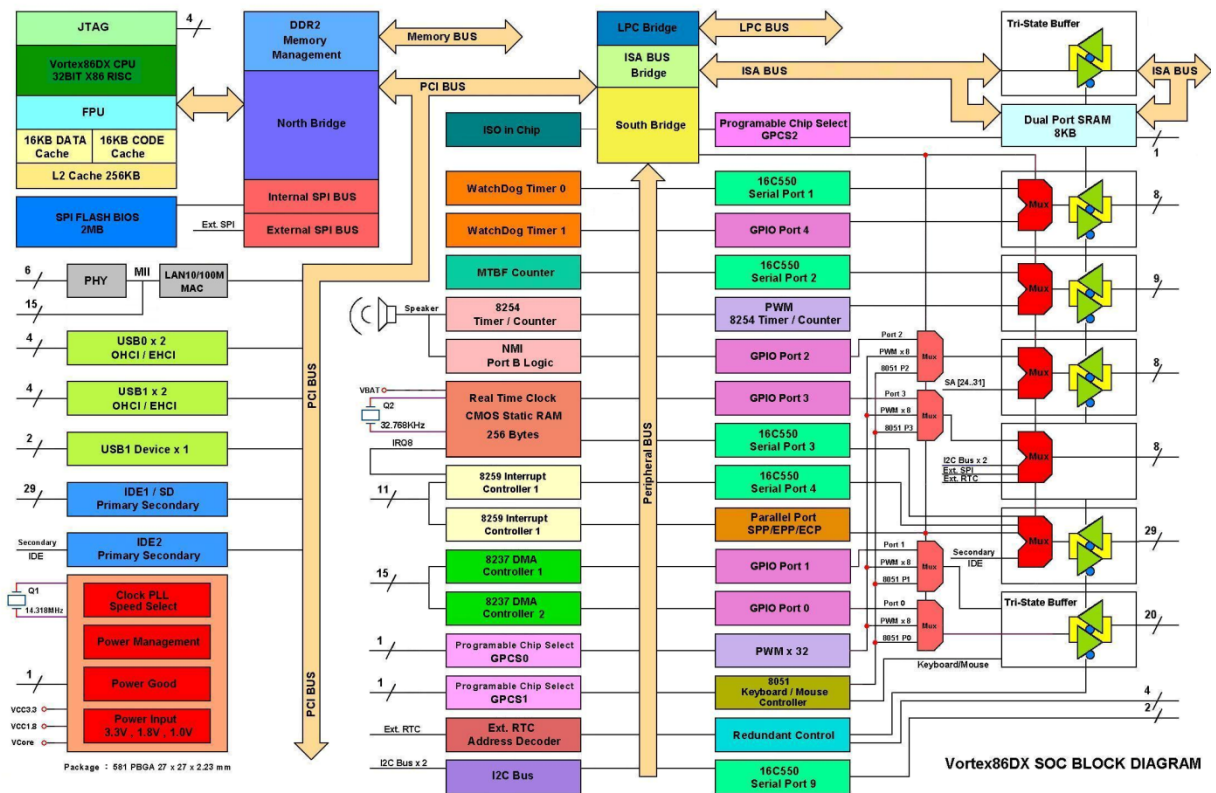

Internal block diagram of the Vortex86DX SoC

Processor functional blocks are

- CPU Core
- Northbridge
- Southbridge
- IDE Controller
- Ethernet Controller
- 2x USB2.0 / USB1.1 Controller
- BIOS flash

For further information, please refer to the datasheet of the DMP Vortex86DX SoC

3.2 MicroSD Slot

On the bottom side of the board a MicroSD slot is located that allows the use of MicroSD cards instead of a hard disk. This slot is connected to the SD part of the primary EIDE port.

UDMA-2 mode for MicroSD and MicroSDHC is supported.

The Micro SD Slot can be selected as boot device in bios setup.

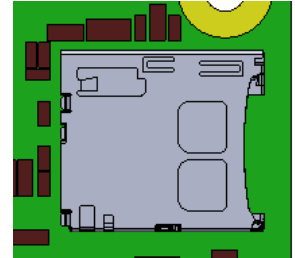

3.3 Ethernet Controller

The Vortex86DX contains a RDC R6040 Fast Ethernet controller.

The Vortex86DX includes both a MAC and PHY. In also has a simple interface to the analog front end, which allows cost effective designs requiring minimal board real estate.

Ethernet Interface

Connector type IDC10 pin header 2.54 mm
Matching connector IDC10 pin female connector 2.54 mm

Pin	Signal	Pin	Signal
1	ETH1-TX+	2	ETH1-TX-
3	ETH1-RX+	4	PE
5	PE	6	ETH1-RX-
7	GND	8	n.c.
9	Link/Activity Signal	10	Duplex Signal

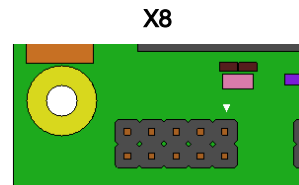

3.4 On Board Power Supply

The on board power controllers generate all necessary voltages from the single supply voltage of 5 Volt.



Note This 3.3 V cannot be used to supply external electronic devices with high power consumption like other PC/104 boards or displays.

Power Connector

Connector type JST B15B-EH-A 15 pin
Matching connector JST EHR-15 15 pin female connector

Pin	Signal (standard)	Signal (5V only)
1	+5V	+5V
2	GND	GND
3	+5V	+5V
4	GND	GND
5	+5V	+5V
6	n.c.	n.c.
7	GND	GND
8	GND	GND
9	n.c.	n.c.
10	n.c.	n.c.
11	GND	GND
12	+12V	n.c.
13	+12V	n.c.
14	GND	GND
15	-12V	n.c.

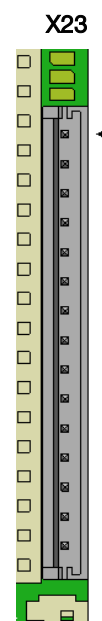

Note The default cable adapter supports the connection of $\pm 12V$ power supply. That pins are routed to the PC/104- bus. If the 5 V only power supply is required leave these pins open. The board can be supplied over the 5 V pins of the PC/104- bus too.

3.5 EIDE Port

An EIDE (Enhanced Integrated Drive Electronics) port is provided by the chipset to connect one drive. The connected device must be set as slave.

To enhance the performance, this port has a 33 MB/s IDE controller in UDMA2 mode per the ATA-4 specification.

The EIDE port is available on a standard 44-pin header (2 mm) for 2.5" hard disks.

An adapter cable is available to connect standard EIDE devices with a 40 pin IDC header.

EIDE Connector

<u>Connector type</u>	IDC44 pin header 2.00 mm
<u>Adapter cables</u>	IDC44 pin female connector 2.00 mm

Pin	Signal	Pin	Signal
1	Reset#	2	GND
3	Data7	4	Data8
5	Data6	6	Data9
7	Data5	8	Data10
9	Data4	10	Data11
11	Data3	12	Data12
13	Data2	14	Data13
15	Data1	16	Data14
17	Data0	18	Data15
19	GND	20	NC
21	DRQ0	22	GND
23	Write	24	GND
25	Read	26	GND
27	Ready	28	CSEL
29	DACK0	30	GND
31	IRQ	32	IOCS16-
33	Address1	34	PD66
35	Address0	36	Address2
37	CS1	38	CS3
39	IDE_LED	40	GND
41	+5 Volt ²	42	+5 Volt
43	GND	44	GND

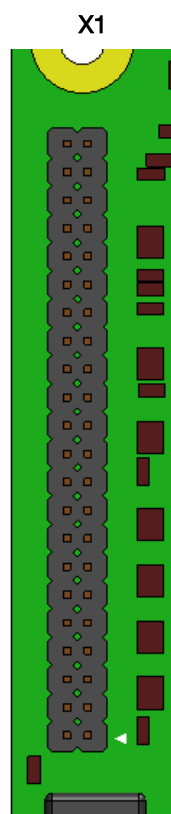

² 1.0 A is the maximum current for each pin

3.6 PS/2 Interface

PS/2-connectors for mouse and keyboard are shared with several system signals. An adapter cable for the PS/2 devices is available.

Keyboard and Mouse Connector

Connector type IDC10 pin header 2.54 mm
Matching connector IDC10 pin female connector 2.54 mm

Pin	Signal	Pin	Signal
1	Speaker	2	Mouse Clock
3	Reset-In	4	Mouse Data
5	KB Data	6	KB Clock
7	GND	8	+5 Volt
9	Ext. Battery	10	Power Button

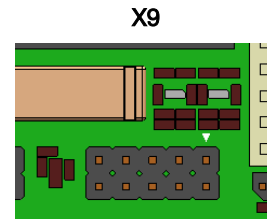

3.7 USB 2.0 Ports

Four standard USB 2.0 host ports are provided at the Cool LiteRunner-86DX. The first and second are located on the IDC10 header X6 (next to the PS pin header) and the third and fourth on the IDC10 header X7(next to the Ethernet pin header).

An adapter cable for all ports is available to use standard USB devices

The USB power supply distributes 0.5 ampere per port. There is a thermal and an over current limit protection. The maximum current limit is at 0.75 to 1.25 ampere (depending on the ambient temperature).

It is possible to use an USB keyboard under MSDOS without special driver software.



Note Not all USB keyboard models are supported.

USB 2.0 Connector 0/1

Connector type IDC10 pin header 2.54 mm
Matching connector IDC10 pin female connector 2.54 mm

Pin	Signal	Pin	Signal
1	USB1-VCC	2	USB0-VCC
3	USB1-Data-	4	USB0-Data-
5	USB1-Data+	6	USB0-Data+
7	USB01-GND	8	USB01-GND
9	Key	10	Unconnected

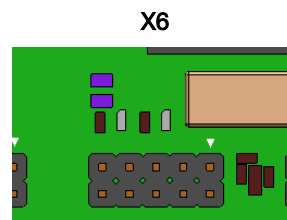

USB 2.0 Connector 2/3

Connector type IDC10 pin header 2.54 mm
Matching connector IDC10 pin female connector 2.54 mm

Pin	Signal	Pin	Signal
1	USB3-VCC	2	USB2-VCC
3	USB3-Data-	4	USB2-Data-
5	USB3-Data+	6	USB2-Data+
7	USB23-GND	8	USB23-GND
9	Key	10	Unconnected

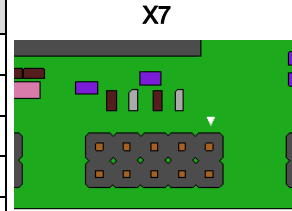

3.8 Serial Ports

The maximum supported baud rates with COM1, COM2, COM3, Com4 and COM9 (for Redundancy mode): up to 750 Kbit/s in high speed mode, 115.2 Kbit/s in normal mode

The serial ports COM1 and COM2 are located on two IDC10 headers "COM1" and "COM2". Adapter cables with standard DSUB-9 male connectors are available. The ports either work in RS232 or RS485 mode, selectable in BIOS or by software. When entering **Chipset → Southbridge Configuration → Multi-Function Port Configuration**, COM Port Modes can be selected by GPIO Port 0 bits 6 and 7:

COM1 mode: GPIO06=0 → RS232, GPIO06=1 → RS485

COM2 mode: GPIO07=0 → RS232, GPIO07=1 → RS485

Termination resistors for RS485 Mode can be set with Jumpers on pin headers as described in this chapter.

To enable transmitters of COM1 and COM2 in RS485 Mode set RTS signal to '1'.

The serial ports COM3, COM4 and COM9 are LVTTTL (Low Voltage TTL) UARTs, which means the UARTs are not connected to a transceiver. An additional difference to COM1 and COM2 is that these serial ports only have RX and TX signals. All three of them have special tasks:

COM3: GPS connection

COM4: FPGA connection (physically: to use it, first a UART has to be implemented into FPGA)

COM9: Part of BoR (Bridge of Redundancy)

The serial ports are programmable in BIOS setup. When entering **Chipset → Southbridge Configuration → Serial/Parallel Port Configuration**, configuration of the serial ports is accessible.

The following settings are possible for COM1 ... COM4:

- **IO-Address:** Disabled / 0x3F8 / 0x2F8 / 0x3E8 / 0x2E8 / 0x10 (normally for COM9 reserved)
- **IRQs:** 3 / 4 / 5 / 6 / 7 / 9 / 10 / 11 / 12 / 14 / 15
- **Bits per Second:** 2400 / 4800 / 9600 / 19200 / 38400 / 56700 / 115200

COM1

Connector type IDC10 pin header 2.54 mm
Matching connector IDC10 pin female connector 2.54 mm

Pin	RS232	RS485	Pin	RS232	RS485
1	DCD	<i>Not used</i>	2	DSR	RXD+
3	RXD	RXD-	4	RTS	TXD+
5	TXD	TXD-	6	CTS	<i>Not used</i>
7	DTR	<i>Not used</i>	8	RI	<i>Not used</i>
9	GND	GND	10	+5 Volt ³	+5 Volt

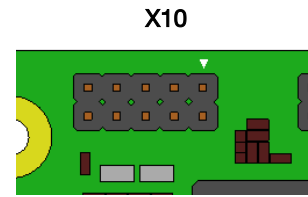

COM2

Connector type IDC10 pin header 2.54 mm
Matching connector IDC10 pin female connector 2.54 mm

Pin	RS232	RS485	Pin	RS232	RS485
1	DCD	<i>Not used</i>	2	DSR	RXD+
3	RXD	RXD-	4	RTS	TXD+
5	TXD	TXD-	6	CTS	<i>Not used</i>
7	DTR	<i>Not used</i>	8	RI	<i>Not used</i>
9	GND	GND	10	+5 Volt ⁴	+5 Volt

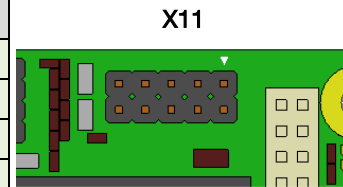

RS485-Termination Jumpers

Connector type IDC8 pin header 2.0 mm
Matching part 2.0 mm jumper

Use 2 mm jumpers to terminate lines correctly.

There are two jumpers COM1 and COM2, respectively.

The RS485 termination jumpers are located at the top of the printed circuit board, see chapter 2.2

Pin	Signal	Pin	Signal
1	TX+_COM1	2	TX-_COM1
3	RX+_COM1	4	RX-_COM1
5	TX+_COM2	6	TX-_COM2
7	RX+_COM2	8	RX-_COM2

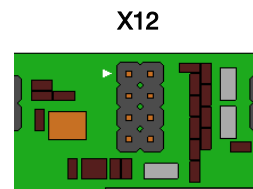

³ 0.5 A is the maximum current for that pin

⁴ 0.5 A is the maximum current for that pin

COM1		COM2	
RS232	RS485	RS232	RS485
① ②	① ②	① ②	① ②
③ ④	③ ④	③ ④	③ ④
⑤ ⑥	⑤ ⑥	⑤ ⑥	⑤ ⑥
⑦ ⑧	⑦ ⑧	⑦ ⑧	⑦ ⑧

Default Settings:
RS232 for COM1 and COM2

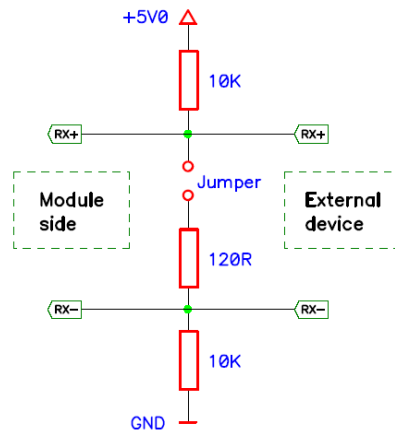

When the jumper is set, the differential pairs are terminated with 120Ω between them. (E.g. RX+ and RX-, on the right picture)

Additionally, positive/negative receive lines are pulled up/down with $10k\Omega$ to 5V/GND in order to protect the transceivers of the Cool LiteRunner-86DX from over voltages.

It is recommended to protect the ports of the external device in the same way!



Caution: Termination Resistors **should not** be used in RS232 Mode! Otherwise, the serial ports will not work.

3.9 Speaker

The speaker signal is located on the IDC10 Header PS/2. A standard PC Speaker can be connected between the signal Speaker and +5 Volt supply.

Connector type IDC10 pin header 2.54 mm
Matching connector IDC10 pin female connector 2.54 mm

Pin	Signal	Pin	Signal
1	Speaker	2	Mouse Clock
3	Reset-In	4	Mouse Data
5	KB Data	6	KB Clock
7	GND	8	+5 Volt
9	Ext. Battery	10	Power Button

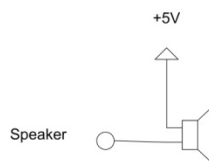
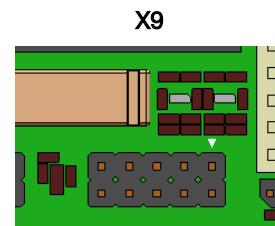

3.10 External Power-Button

The Power-Button signal is located on the IDC10 Header PS/2. To power up/down the board the signal Power-Button must be pulled to GND.

Connector type IDC10 pin header 2.54 mm
Matching connector IDC10 pin female connector 2.54 mm

Pin	Signal	Pin	Signal
1	Speaker	2	Mouse Clock
3	Reset-In	4	Mouse Data
5	KB Data	6	KB Clock
7	GND	8	+5 Volt
9	Ext. Battery	10	Power Button

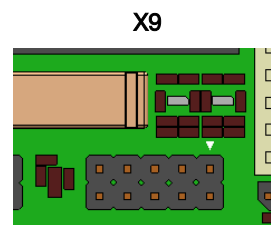

3.11 Reset-In Signal

The "Reset-In" signal is located on the IDC10 Header PS/2. To reset the board, the signal "Reset-In" must be pulled to GND.

Connector type IDC10 pin header 2.54 mm
Matching connector IDC10 pin female connector 2.54 mm

Pin	Signal	Pin	Signal
1	Speaker	2	Mouse Clock
3	Reset-In	4	Mouse Data
5	KB Data	6	KB Clock
7	GND	8	+5 Volt
9	Ext. Battery	10	Power Button

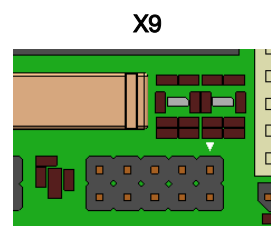

3.12 External Battery

A connected battery should replace or support the mounted one to keep date and time active during the board is mechanical off.

It is recommended to use a model with 3 Volt, but it will also work with power suppliers up till 3.6 Volt.

The BIOS setting will get lost if the power supplier falls down to 2.4 Volt.

For live time calculation there are 2.3 μ A (25°C) needed when the board is not running.

That value can rise up with higher temperatures.

Connector type IDC10 pin header 2.54 mm
Matching connector IDC10 pin female connector 2.54 mm

Pin	Signal	Pin	Signal
1	Speaker	2	Mouse Clock
3	Reset-In	4	Mouse Data
5	KB Data	6	KB Clock
7	GND	8	+5 Volt
9	Ext. Battery	10	Power Button

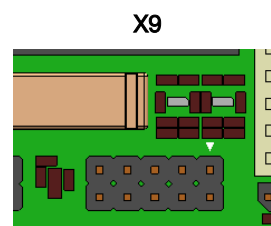

3.13 Supervisory

The Cool LiteRunner-86DX provides a 30-pin Supervisory Connector on its bottom side. The table below shows the assignment of the different signals.

The GPIOs pins can be used in normal I/O mode or in PWM/SERVO mode:

- In I/O mode the input detects shortage to GND. The output level is 3.3V.
- In PWM or SERVO mode frequency, time and pulse widths can be configured to generate PWM signals. This can be used for engine control.

The ESPI bus is the same connected to the bootable flash. Set the Flash to HOLD in the BIOS and the ESPI bus can be use for a different purpose.

The GPSPI bus access can be used for external FPGA flash programming.

Connector type Hirose DF14 30 pin header 1.25 mm, single row
Matching connector Hirose DF14-30S-1.25C, Part number 538-0012-3 00

Pin	Signal	Pin	Signal
1	+5 V ⁵	16	GPIO15
2	+3.3 V ⁶	17	GPIO16
3	GPIO20	18	GPIO17
4	GPIO21	19	ESPI_CS#
5	GPIO22	20	ESPI_MISO
6	GPIO23	21	ESPI_MOSI
7	GPIO24	22	ESPI_CLK
8	GPIO25	23	I2C_SCL
9	GPIO26	24	I2C_SDA
10	GPIO27	25	GPSPI_CS#
11	GPIO10	26	GPSPI_SCK
12	GPIO11	27	GPSPI_MISO
13	GPIO12	28	GPSPI_MOSI
14	GPIO13	29	GPSPI_PROG_B
15	GPIO14	30	GND

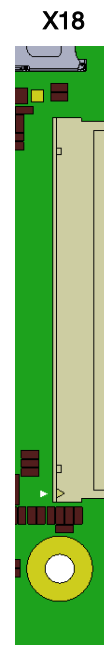

⁵ 1.0 A is the maximum current for each pin

3.14 Mini-PCI BUS Interface

The Mini-PCI specification defines a small form factor daughter card for the 32bit PCI bus that can be used on CPU-boards in which standard PCI cards cannot be used due to mechanical constraints. A CPU board with such a card can easily be enhanced with new functionality. The onboard Type IIIA Mini-PCI Slot can be used to extend the system easily with peripheral functionality, like VGA and LVDS, WLAN modules, Fire Wire-, Serial- and USB 2.0- ports.

Several Mini-PCI extension boards are available on request.

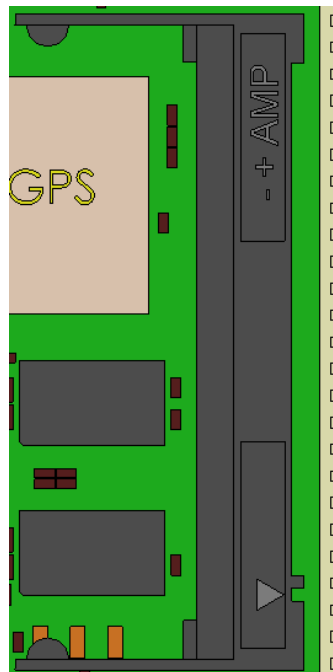
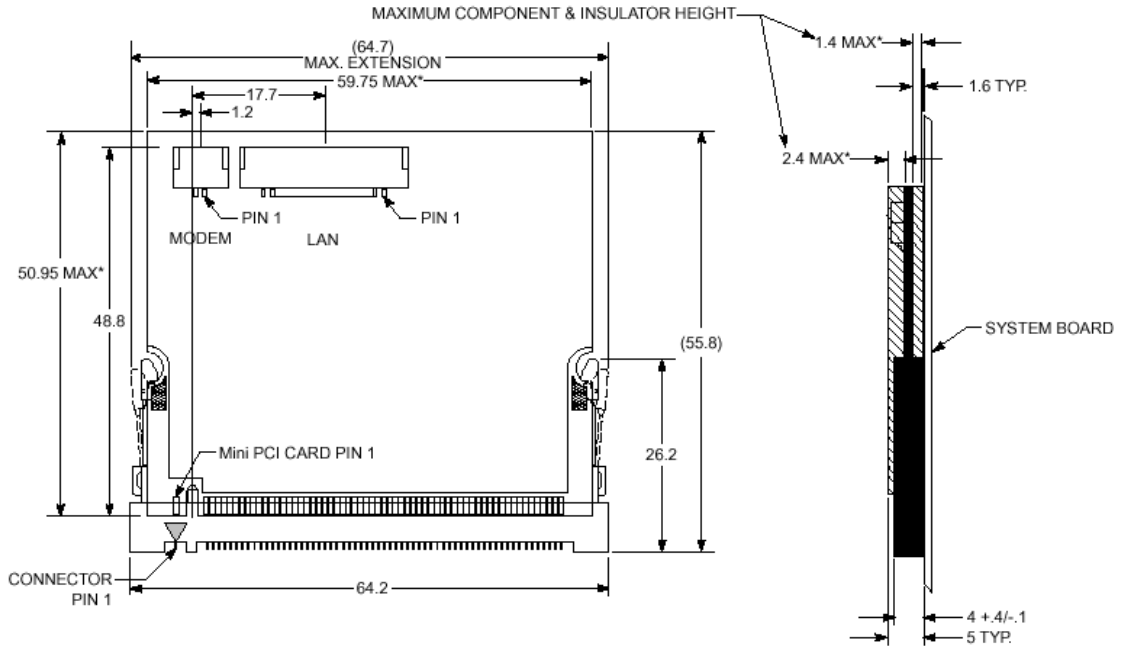

X3

Mini-PCI Connector (X3)

Pin	Signal	Pin	Signal	Pin	Signal	Pin	Signal
1	n.c.	2	n.c.	69	GND	70	3.3V
...	n.c.	16	n.c.	71	PCI_PERR#	72	PCI_DEVSEL#
17	PCI_INTA#	18	5V	73	PCI_C/BE1#	74	GND
19	3.3V	20	PCI_INTB#	75	PCI_AD14	76	PCI_AD15
21	n.c.	22	n.c.	77	GND	78	PCI_AD13
23	GND	24	3.3V SBY	79	PCI_AD12	80	PCI_AD11
25	CLK_33_MPCI_R	26	PCI_RST#	81	PCI_AD10	82	GND
27	GND	28	3.3V	83	GND	84	PCI_AD09
29	REQ1_MPCI#	30	GNT1_MPCI#	85	PCI_AD08	86	PCI_C/BE0#
31	3.3V	32	GND	87	PCI_AD07	88	3.3V
33	PCI_AD31	34	PME#	89	3.3V	90	PCI_AD06
35	PCI_AD29	36	n.c.	91	PCI_AD05	92	PCI_AD04
37	GND	38	PCI_AD30	93	n.c.	94	PCI_AD02
39	PCI_AD27	40	3.3V	95	PCI_AD03	96	PCI_AD00
41	PCI_AD25	42	PCI_AD28	97	5V	98	n.c.
43	n.c.	44	PCI_AD26	99	PCI_AD01	100	n.c.
45	PCI_C/BE3#	46	PCI_AD24	101	GND	102	GND
47	PCI_AD23	48	PCI_AD23	103	n.c.	104	GND
49	GND	50	GND	105	n.c.	106	n.c.
51	PCI_AD21	52	PCI_AD22	107	n.c.	108	n.c.
53	PCI_AD19	54	PCI_AD20	109	n.c.	110	n.c.
55	GND	56	PCI_PAR	111	n.c.	112	n.c.
57	PCI_AD17	58	PCI_AD18	113	GND	114	GND
59	PCI_C/BE2#	60	PCI_AD16	115	n.c.	116	n.c.
61	PCI_IRDY#	62	GND	117	GND	118	GND
63	3.3V	64	PCI_FRAME#	119	GND	120	GND
65	n.c.	66	PCI_TRDY#	121	n.c.	122	n.c.
67	PCI_SERR#	68	PCI_STOP#	123	5V	124	n.c.



Note: All VI/O pins are connected to +3.3V.
The maximum current is limited to 2.0 A for each voltage.

3.15 PC/104 Bus Interface

The PC/104 bus is a modification of the industry standard (ISA) PC bus specified in IEEE P966. The PC/104 bus has different mechanics than P966 to allow the stacking of modules. The main features are:

- Supports programmable extra wait state for ISA cycles
- Supports I/O recovery time for back-to-back I/O cycles

The following table shows the pin assignment of the PC/104 connector.



Note: -5 V on the PC/104 connector is not supported on this board.
± 12 Volt is can be supplied by power connector

PC/104 Bus Connector

Pin	D	C
0	GND	GND
1	MEMCS16	SBHE
2	IOCS16	LA23
3	IRQ 10	LA22
4	IRQ 11	LA21
5	IRQ 12	LA20
6	IRQ 15	LA19
7	IRQ 14	LA18
8	DACK	LA17
9	DRQ	MEMR
10	DACK	MEMW
11	DRQ	SD8
12	DACK	SD9
13	DRQ	SD10
14	DACK	SD11
15	DRQ	SD12
16	+5 Volt	SD13
17	MASTER	SD14
18	GND	SD15
19	GND	KEY (n.c.)

Pin	A	B
1	IOCHCK	GND
2	D7	RSTDRV
3	D6	+5 Volt
4	D5	IRQ9
5	D4	n.c.
6	D3	DRQ2
7	D2	-12 Volt
8	D1	ENDXFER
9	D0	+12 Volt
10	IOCHRDY	KEY (n.c.)
11	AEN	SMEMW
12	A19	SMEMR
13	A18	IOW
14	A17	IOR
15	A16	DACK3
16	A15	DRQ3
17	A14	DACK1
18	A13	DRQ1
19	A12	REFRESH
20	A11	SYSCLK
21	A10	IRQ7
22	A9	IRQ6
23	A8	IRQ5
24	A7	IRQ4
25	A6	IRQ3
26	A5	DACK2
27	A4	TC
28	A3	BALE
29	A2	+5 Volt
30	A1	OSC
31	A0	GND
32	GND	GND

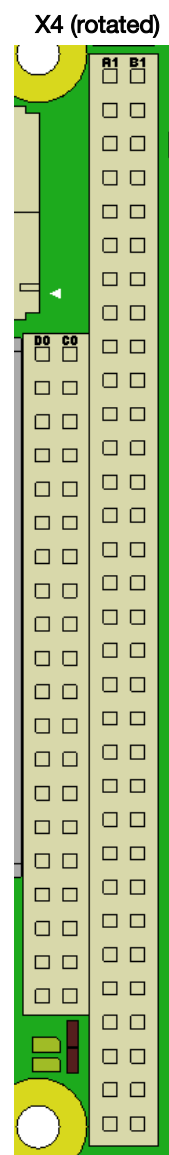

3.16 JTAG-CPU (BIOS recovery)

The BIOS flash is integrated in the Vortex86DX.

The BIOS can be updated with an update tool via the internal SPI bus.

Full BIOS recovery can be done via JTAG. The JTAG port of the Vortex86DX can be found next to the RS485 termination connector.

Needed for full BIOS Recovery: LPT-to-JTAG cable, BIOS file and JFlash

Connector type IDC12 pin header 2.54 mm
Matching connector IDC12 pin female connector 2.54 mm

Pin	Signal	Pin	Signal
1	+5 Volt	2	+3.3 Volt
3	GND	4	GND
5	V86DX_TCK	6	FPGA_TCK
7	V86DX_TDO	8	FPGA_TDO
9	V86DX_TDI	10	FPGA_TDI
11	V86DX_TMS	12	FPGA_TMS

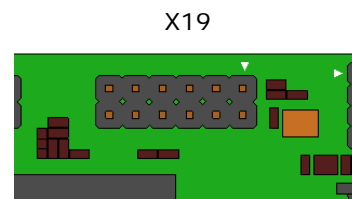

3.17 FPGA (Field Programmable Gate Array)

For the first time a LiPPERT board has a FPGA freely useable for I/O extension by the customer. It is a Xilinx Spartan-3A FPGA with 200K Gates. The programming software ("ISE WebPack") is freeware and can be downloaded from the Xilinx home page.

On hardware side the FPGA is physically connected to the LPC bus and the COM4 of the Vortex86DX. By implementing a LPC- or UART- slave device into the FPGA a data exchange can take place between FPGA and Vortex86DX.

The FPGA can boot from JTAG or SPI-Flash. The boot mode is SMC controlled and can be changed with the LEMT tool.

For using JTAG, a Xilinx Platform-Cable (USB or LPT) is needed.

The SPI-Flash can be programmed externally over the GP-SPI pins on the Supervisory (e.g. with the Xilinx Platform-Cable) or internally from Vortex86DX over GP-SPI (uses GPIO00 ... 04) with the special flash tool V86DX_GPSPi (downloadable on the LiPPERT homepage).



Note: For further information see CLR86DX-FPGA-Manual

3.18 JTAG-FPGA

The JTAG port of the FPGA can be found between JTAG-CPU port and COM1. The JTAG port can be used to program the FPGA. Therefore the FPGA boot mode has to be switched to JTAG in the LEMT tool

Connector type IDC12 pin header 2.54 mm
Matching connector IDC12 pin female connector 2.54 mm

Pin	Signal	Pin	Signal
1	+5 Volt	2	+3.3 Volt
3	GND	4	GND
5	V86DX_TCK	6	FPGA_TCK
7	V86DX_TDO	8	FPGA_TDO
9	V86DX_TDI	10	FPGA_TDI
11	V86DX_TMS	12	FPGA_TMS

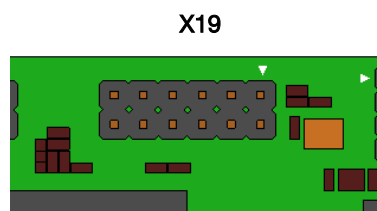

3.19 FPGA-I/O Connectors

The I/Os are routed directly to four IDC30 (2mm) connectors. That offers the possibility of a flexible and low-cost Board-to-board or board-to-wire connection. Two connectors are organized as differential pairs and “Global Clock” usage pins. The other two are single ended organized.

Differential signal and “Global Clock” connector 1 (X13)

Connector type IDC30 pin header 2.0 mm
Matching connector IDC30 pin female connector 2.0 mm

Pin	Signal	Pin	Signal
1	3.3 V ⁶	2	3.3 V
3	FPGA_IO_DIFF0_P	4	FPGA_IO_DIFF0_N
5	FPGA_IO_DIFF1_P	6	FPGA_IO_DIFF1_N
7	FPGA_IO_DIFF2_P	8	FPGA_IO_DIFF2_N
9	FPGA_IO_DIFF3_P	10	FPGA_IO_DIFF3_N
11	FPGA_IO_DIFF4_P	12	FPGA_IO_DIFF4_N
13	FPGA_IO_DIFF5_P	14	FPGA_IO_DIFF5_N
15	FPGA_IO_GCLK_DIFF6_P	16	FPGA_IO_GCLK_DIFF6_N
17	FPGA_IO_GCLK_DIFF7_P	18	FPGA_IO_GCLK_DIFF7_N
19	FPGA_IO_DIFF8_P	20	FPGA_IO_DIFF8_N
21	FPGA_IO_DIFF9_P	22	FPGA_IO_DIFF9_N
23	FPGA_IO_DIFF10_P	24	FPGA_IO_DIFF10_N
25	FPGA_IO_DIFF11_P	26	FPGA_IO_DIFF11_N
27	FPGA_IO_DIFF12_P	28	FPGA_IO_DIFF12_N
29	GND	30	GND

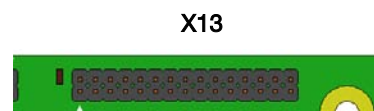

⁶ 0.5 A is the maximum current for that pin

Differential signal and “Global Clock” connector 2 (X15)

Connector type IDC30 pin header 2.0 mm
Matching connector IDC30 pin female connector 2.0 mm

Pin	Signal	Pin	Signal
1	3.3 V ⁷	2	3.3 V ⁹
3	FPGA_IO_DIFF13_P	4	FPGA_IO_DIFF13_N
5	FPGA_IO_DIFF14_P	6	FPGA_IO_DIFF14_N
7	FPGA_IO_DIFF15_P	8	FPGA_IO_DIFF15_N
9	FPGA_IO_DIFF16_P	10	FPGA_IO_DIFF16_N
11	FPGA_IO_GCLK_DIFF17_P	12	FPGA_IO_GCLK_DIFF17_N
13	FPGA_IO_GCLK_DIFF18_P	14	FPGA_IO_GCLK_DIFF18_N
15	FPGA_IO_GCLK_DIFF19_P	16	FPGA_IO_GCLK_DIFF19_N
17	FPGA_IO_GCLK_DIFF20_P	18	FPGA_IO_GCLK_DIFF20_N
19	FPGA_IO_DIFF21_P	20	FPGA_IO_DIF21_N
21	FPGA_IO_DIFF22_P	22	FPGA_IO_DIFF22_N
23	FPGA_IO_DIFF23_P	24	FPGA_IO_DIFF23_N
25	FPGA_IO_DIFF24_P	26	FPGA_IO_DIFF24_N
27	FPGA_IO_DIFF25_P	28	FPGA_IO_DIFF25_N
29	GND	30	GND

X15

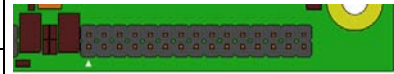

Single ended signal connector 1 (X14)

Connector type IDC30 pin header 2.0 mm
Matching connector IDC30 pin female connector 2.0 mm

Pin	Signal	Pin	Signal
1	3.3 V ⁹	2	3.3 V ⁹
3	FPGA_IO_SE14	4	FPGA_IO_SE15
5	FPGA_IO_SE16	6	FPGA_IO_SE17
7	FPGA_IO_SE18	8	FPGA_IO_SE19
9	FPGA_IO_SE20	10	FPGA_IO_SE21
11	FPGA_IO_SE22	12	FPGA_IO_SE23
13	FPGA_IO_SE24	14	FPGA_IO_SE25
15	FPGA_IO_SE26	16	FPGA_IO_SE27
17	FPGA_IO_SE28	18	FPGA_IO_SE29
19	FPGA_IO_SE30	20	FPGA_IO_SE31
21	FPGA_IO_SE32	22	FPGA_IO_SE33
23	FPGA_IO_SE34	24	FPGA_IO_SE35
25	FPGA_IO_SE36	26	FPGA_IO_SE37
27	FPGA_IO_SE38	28	FPGA_IO_SE39
29	GND	30	GND

X14



^{7,9} 0.5 A is the maximum current for that pin

Single ended signal, VCCO and VREF connector 1 (X16)

Connector type IDC30 pin header 2.0 mm
Matching connector IDC30 pin female connector 2.0 mm

Pin	Signal	Pin	Signal
1	3.3 V ⁸	2	3.3 V ¹⁰
3	3.3 V ¹⁰	4	VREF0
5	3.3 V ¹⁰	6	VCCO0
7	3.3 V ¹⁰	8	VREF1
9	3.3 V ¹⁰	10	VCCO1
11	3.3 V ¹⁰	12	VREF2
13	3.3 V ¹⁰	14	VCCO2
15	FPGA_IO_SE0	16	FPGA_IO_SE1
17	FPGA_IO_SE2	18	FPGA_IO_SE3
19	FPGA_IO_SE4	20	FPGA_IO_SE5
21	FPGA_IO_SE6	22	FPGA_IO_SE7
23	FPGA_IO_SE8	24	FPGA_IO_SE9
25	FPGA_IO_SE10	26	FPGA_IO_SE11
27	FPGA_IO_SE12	28	FPGA_IO_SE13
29	GND	30	GND

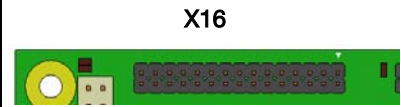

X16

^{8,10} 0.125 A is the maximum current for that pin

3.20 BoR – “Bridge of Redundancy” connector

To use the redundancy mode connect 2 Cool LiteRunner-86DX over the PC104 bus and the Redundancy Cable.

The following settings have to be done in the BIOS:

Chipset → Southbridge Configuration

→ Redundancy Control Configuration:

- Dual Port 4KB SRAM: Enabled
 - SRAM Command: MEMR/W 8bit
 - SRAM Start Address: 000D0000
 - SRAM Mast Compare Bit: FFFFF000
- SB Serial Port 9: 10
 - Serial Port IRQ 9: IRQ9
- GPIO PORT0 System Fail: TRI-State
- GPIO PORT1 System Fail: TRI-State
- GPIO PORT2 System Fail: TRI-State
- LPT PORT System Fail: TRI-State
- UART1 System Fail: TRI-State
- UART2 System Fail: TRI-State
- UART3 System Fail: TRI-State
- UART4 System Fail: TRI-State

→ GPCS Configuration:

- GPCS0 Function: Enabled
 - GPCS0 Command: MEMR/W 8bit
 - GPCS0 Start Address: 000C8000
 - GPCS0 Mask Compare Bit: FFFFC000

Connector type
Matching connector

Hirose DF13 10 pin header 1.25 mm
Hirose DF13-10S-1.25C, part number 536-0009-6 00

Pin	Signal
1	GPCS1#
2	GPCS0#
3	COM9_SIN
4	COM9_SOUT
5	SYS_FAIL_OUT#
6	EXT_SYS_FAIL_IN#
7	EXT_SWITCH_FAIL#
8	EXT_GPCS#
9	GND
10	GND

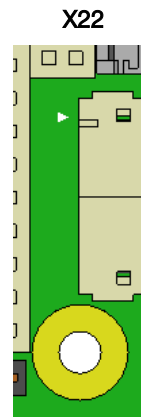

Cable plan for the "Bridge of Redundancy"

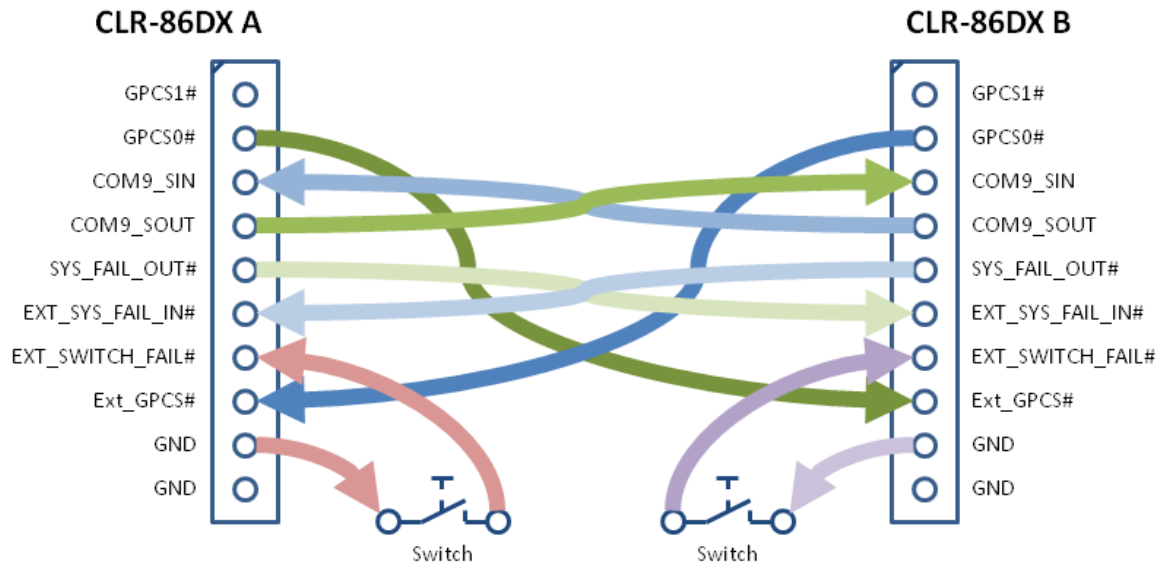

Cool Lite Runner - 86DX: Concept of Redundancy

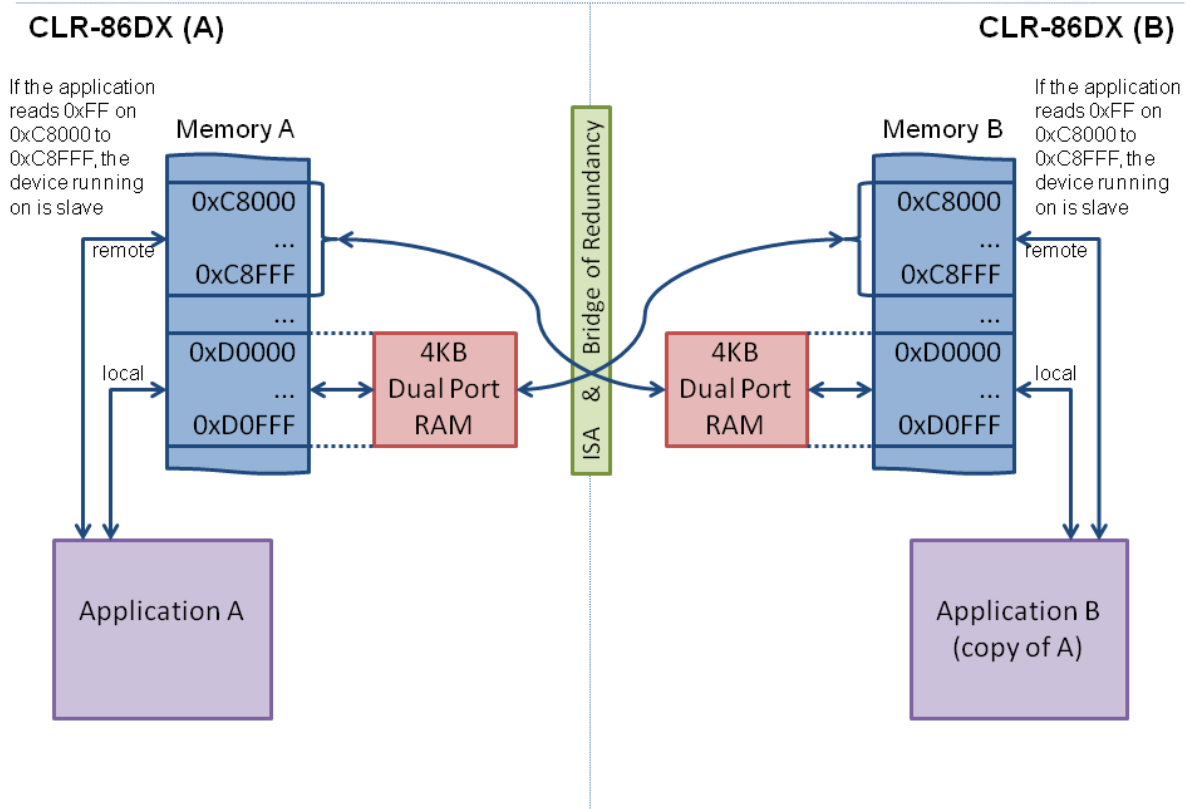

3.21 GPS – Global Positioning System

The onboard GPS module of the Cool LiteRunner-86DX is connected to the COM3 port of the Vortex86DX. It is capable of **Indoor Tracking**, which means the sensibility is high enough to get satellite contact even indoor or canyons. To make it not only an up-to-date technology but even an up-to-tomorrow device it is **Galileo-Ready**. As soon as the Galileo satellite system is online only a firmware update is needed to use it. That will cause a much better and securer tracking because the number of reachable satellites approximately doubles.

To prevent the effect of Windows interpreting traffic on COM3 as Serial Mouse the GPS is controlled by the SMC and has to be activated with the LEMT tool.

An active or passive antenna can be connected:

Connector type Hirose U.FL-R-SMT Connector
Matching connector Hirose U.FL series

X17

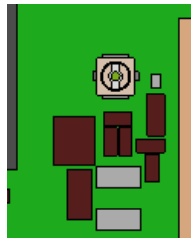

3.22 SPI Flash

In real mode operating systems (INT13 compatible) like DOS the Flash is accessible as drive A. It is like a virtual floppy drive with 8MB size. There is no special driver for DOS needed.

Protected mode operating systems like Windows or Linux need a special driver or program to access the Flash. A WinCE driver is available as well as a Linux program to access the SPI Flash.

In the BIOS boot device list the drive is called "SCSI Card:D8000".

3.23 SMC Service Connector

The service connector is for internal diagnostics and not for customer purpose.

X20

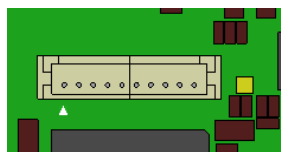

3.24 Battery Jumper

The battery jumper connects the orange onboard battery to the system. The battery is needed to save Date and time in the BIOS. By default the jumper should be set on pin 1-2.

For delivery the jumper is half-stacked on one pin to save the battery

Delivery	Default
A diagram showing two pins labeled '1' and '2' in circles. An orange rectangular jumper is placed over both pins.	A diagram showing two pins labeled '1' and '2' in circles. An orange rectangular jumper is placed over both pins.

4 Using the Module

4.1 Watchdog

Two watchdogs are integrated in the Vortex86DX and one in the SMC (managed by the LEMT).

The Vortex86DX watchdogs can be configured in the BIOS or by programming the watchdog registers.

The SMC watchdog activation is caused by under voltage protection. The watchdog LED gets flashed after restart, but only if the power supply had stood over 4.2 Volt.

4.2 LEMT functions

The onboard Microcontroller implements power sequencing and LEMT (LIPPERT Enhanced Management Technology) functionality. The microcontroller communicates via the System Management Bus with the CPU/Chipset. The following functions are implemented:

- Total operating hours counter
Counts the number of hours the module has been run in minutes.
- On-time minutes counter
Counts the seconds since last system start.
- Power cycles counter
- Watchdog Timer
Set / Reset / Disable Watchdog Timer.
- System Restart Cause
Power loss / Watchdog / External Reset.
- Flash area
1kB Flash area for customer data
- Protected Flash area
128 Bytes for Keys, ID's, etc. can stored in a write- and clear-protect able area.
- Board Identify
Vendor / Board / Serial number
- Vortex86DX startup frequency control
- FPGA boot mode (JTAG, SPI)
- FPGA suspend control
- GPS reset control
- MicroSD write protection control

LEMT Tools are available for Windows and Linux, LEMT functionality can also be used in applications. Please ask our support for the LEMT software manual and technical manual regarding more details on functionality and how to use it.

Board Specific LEMT functions

Voltages

The SMC of the CLR-86DX implements a Voltage Monitor and samples several Onboard-Voltages. The Voltages can be read by calling the LEMT function "Get Voltages". The function returns a 16 Bit value divided in Hi-Byte (MSB) and Lo-Byte (LSB).

ADC Channel	Voltage Name	Voltage Formula [V]
0	---	---
1	---	---
2	---	---
3	---	---
4	+VCORE_CPU	$(MSB \ll 8 + LSB) * 3.3 / 1024$
5	+V1.2	$(MSB \ll 8 + LSB) * 3.3 / 1024$
6	+V1.8	$(MSB \ll 8 + LSB) * 3.3 / 1024$
7	+V3.3	$(MSB \ll 8 + LSB) * 1.100 * 3.3 / 1024$

TS#-Events

TS# is activated by a Temperature sensor when a device reaches its critical temperature and released when the device is back into its normal temperature range. This counter gives the User information of emperature/Cooling problems. This counter is cleared when the system is removed from power. The CLR-86DX only monitors the Board-temperature and does not support TS#-Events.

Exception Codes

In case of an error the SMC shows a blink code on the STATUS-LED. This error code is also reported by the SMC Flags register. The Exception Code is not stored in the Flash Storage and is cleared when the power is removed. Therefore the "Clear Exception Code"-Command is not supported.

Exception Code	Error Message
0	NO_ERROR
2	NO_SUSCLK
3	NO_SLP_S5
4	NO_SLP_S3
5	RESET_FAIL
6	NO_PWRGD_SBY
7	NO_PWRGD_IMVP
8	NO_PWRGD_SYS
9	NO_PWRGD_MEM
14	+VCORE_CPU
15	+V1.2
16	+V1.8
17	+V3.3
18	BIOS_FAIL
19	LOW_5V0SB

SMC Flags

The SMC Flags return the last detected Exception Code since Power-up. The upper 3 bits of the SMC Flags register are reserved for future use.

SMC Status

This register show of the status of SMC controlled signals on the CLR-86DX.

Status Bit	Signal
0	SMC_WDACTIVE#
1	-
2	-
3	-
4	-
5	-
6	-
7	-

Special Features

These features can be read and modified with GPIO register or SOFTSTRAP register.

GPIO register settings are non-permanent. After Power-Off / Reset the register will be reset to default values. For Example: GPS is turned off while start-up. Operating systems with automated hardware detection interpret GPS messages on COM3 as mouse messages and install a COM-mouse driver. So the system is uncontrollable.

SOFTSTRAP register settings are permanent. These settings will remain after Power-Off / Reset.

Action	Command (Linux)	Command (Windows XP)
Read SOFTSTRAP register	<code>./lemt getsstrap</code>	<code>lemt.exe getsstrap</code>
Write SOFTSTRAP register	<code>./lemt setsstrapotf <value></code>	<code>lemt.exe setsstrapotf <value></code>
Read GPIO register	<code>./lemt getgpio</code>	<code>lemt.exe getgpio</code>
Write GPIO register	<code>./lemt setgpio <value></code>	<code>lemt.exe setgpio <value></code>

GPIO register settings:

Bit(s)	Description	Value
0	GPS activate	0 = off 1 = on
7 to 1	reserved	

SOFTSRAP register settings:

Bit(s)	Description	Value
2 to 0	FPGA boot mode (M2,M1,M0)	001 = Master SPI 101 = JTAG
4 to 3	reserved	
5	SD card WP	1=SD Write Protect
7 to 6	reserved	

To change settings, read register, change bits to the value you need and write it back.

4.3 BIOS

The Cool LiteRunner-86DX is delivered with an AMI BIOS. The default setting guarantees a "ready to run" system, even without a BIOS setup backup battery.

The BIOS is located in flash memory and can be easily updated on board with software under DOS.

All setup changes of the BIOS are stored in the CMOS RAM.

The soldered battery will keep that information over 3 years without any activation of the board. That depends on the use of the board. When power is up, the battery does not lose capacity.

Battery Jumper

With the Jumper "Battery", see chapter 2.2, the battery can be disconnected from the system.

If the board should be stored for longer times, this is the best solution to save the capacity. The battery loses 1% of its capacity over self-discharge per year without the jumper.

Configuring the BIOS

Pressing on power up starts the BIOS setup utility.

Pressing <F11> on power up starts the boot menu.

Pressing <END> on power up resets settings to default.

Main screen after entering the BIOS (BIOS version: CLR86002.BIN):

```

Main  Advanced  PCIPnP  Boot  Security  Chipset  Exit
-----
System Overview
-----
CLR86002.BIN (LIPPERT Embedded Computers GmbH)

Processor
Vortex86DX A9121
Speed      :600MHz

System Memory
Size       :512MB
Speed     :333MHz

System Time  [08:12:08]
System Date  [Fri 08/05/2011]

CPU MTBF    :16777167 Hour(s) Remaining
System Fault :0 Time(s)

↔ Select Screen
↑↓ Select Item
+- Change Field
Tab Select Field
F1  General Help
F10 Save and Exit
ESC Exit

v02.69 (C) Copyright 1985-2010, American Megatrends, Inc.
```

The **IDE configuration** can be found in the **Advanced** tab. Primary IDE Master is the MicroSD slot. Secondary IDE is available on 44pin header. Native IDE mode is faster than legacy, on trouble with devices, try legacy mode. The Standard IDE Compatible option simulates an Intel controller. That simplifies driver installations.

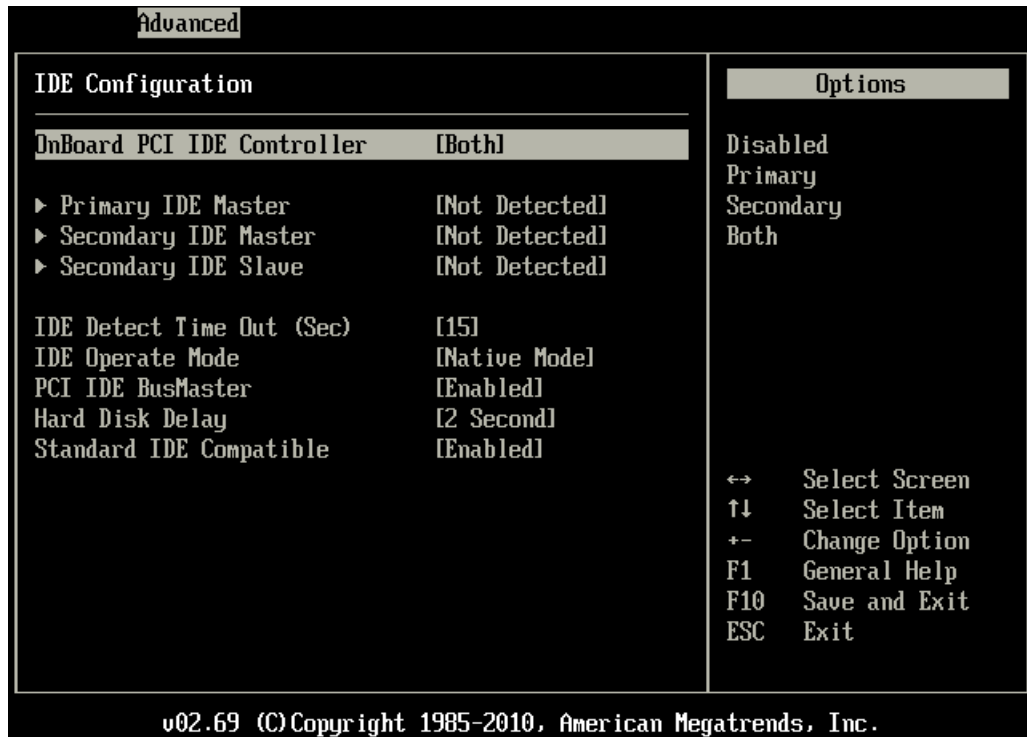

The **USB configuration** can also be found in the **Advanced** tab. There will be a list of connected USB devices.

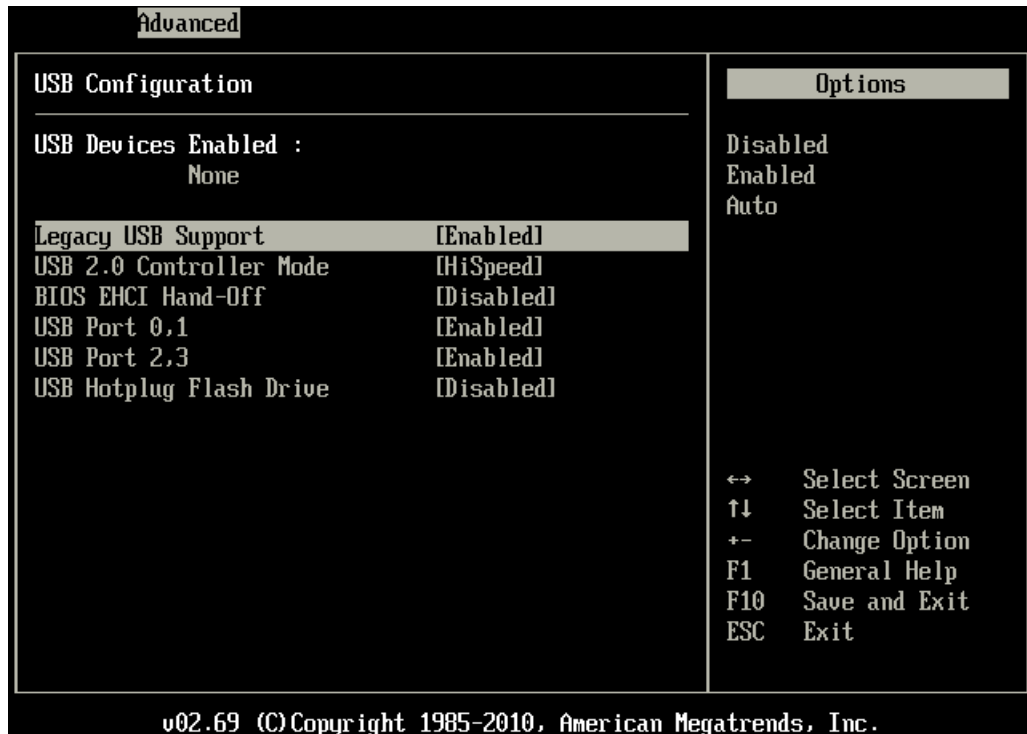

In the **PCIPnP** tab the available resources can be managed. To get IRQs available on ISA / PC104 bus set to "Reserved"

Main Advanced PCIPnP Boot Security Chipset Exit	
Advanced PCI/PnP Settings	
WARNING: Setting wrong values in below sections may cause system to malfunction.	
Clear NURAM	[No]
Plug & Play O/S	[No]
Palette Snooping	[Disabled]
IRQ3	[Reserved]
IRQ4	[Reserved]
IRQ5	[Available]
IRQ6	[Available]
IRQ9	[Available]
IRQ10	[Reserved]
IRQ11	[Reserved]
IRQ12	[Available]
IRQ14	[Available]
IRQ15	[Available]

Options
 No
 Yes

 ↔ Select Screen
 ↑↓ Select Item
 +- Change Option
 F1 General Help
 F10 Save and Exit
 ESC Exit

v02.69 (C) Copyright 1985-2010, American Megatrends, Inc.

Main Advanced PCIPnP Boot Security Chipset Exit	
IRQ4	[Reserved]
IRQ5	[Available]
IRQ6	[Available]
IRQ9	[Available]
IRQ10	[Reserved]
IRQ11	[Reserved]
IRQ12	[Available]
IRQ14	[Available]
IRQ15	[Available]
DMA Channel 0	[Available]
DMA Channel 1	[Available]
DMA Channel 3	[Available]
DMA Channel 5	[Available]
DMA Channel 6	[Available]
DMA Channel 7	[Available]
Reserved Memory Size	[Disabled]
▶ IRQ Trigger Type Settings	

↔ Select Screen
 ↑↓ Select Item
 Enter Go to Sub Screen
 F1 General Help
 F10 Save and Exit
 ESC Exit

v02.69 (C) Copyright 1985-2010, American Megatrends, Inc.

The boot order and other boot options can be set in the **Boot** tab. In this tab will be a list of available bootable devices. In this picture, there are no bootable devices.

The device "SCSI Card:D8000" is the virtual Floppy drive (8MB bootable flash).

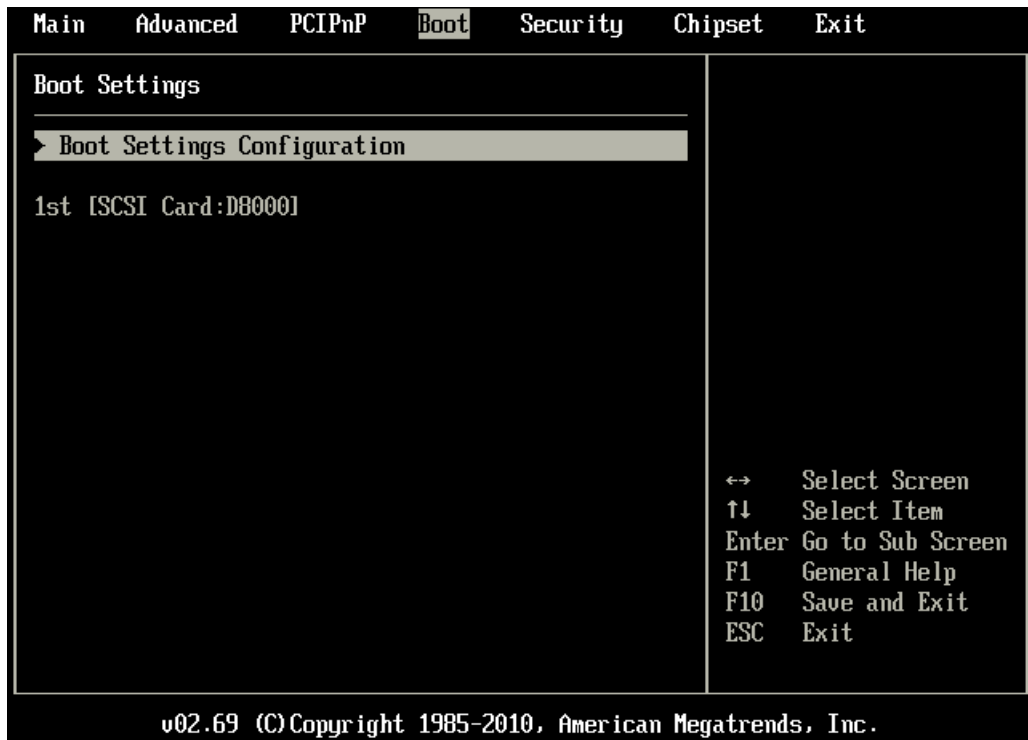

The LAN boot (PXE and RPL supported) configuration is not in the Boot tab but can be found in the **Advanced** Tab:



The **Chipset** tab contains the “South Bridge” settings for several I/O and legacy devices, as well as the redundancy control.

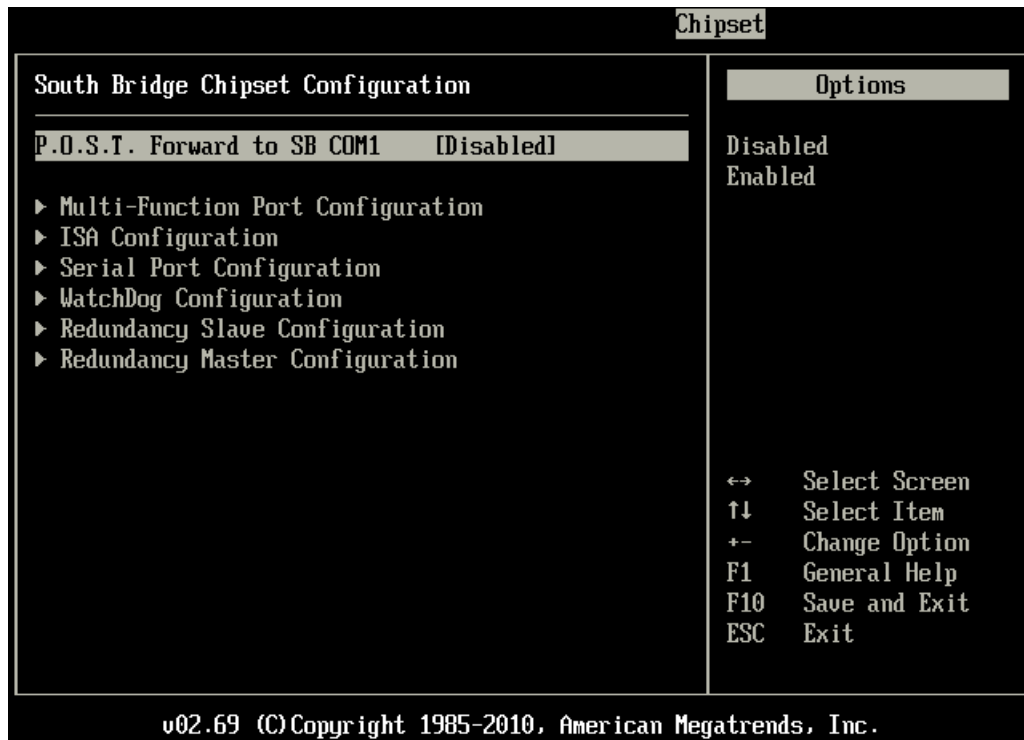

Serial Port Configuration: port 1 and 2 are free available UARTs operating in RS232 or RS485 mode, Port 3 is connected to the GPS module and port 4 is connected to the FPGA.

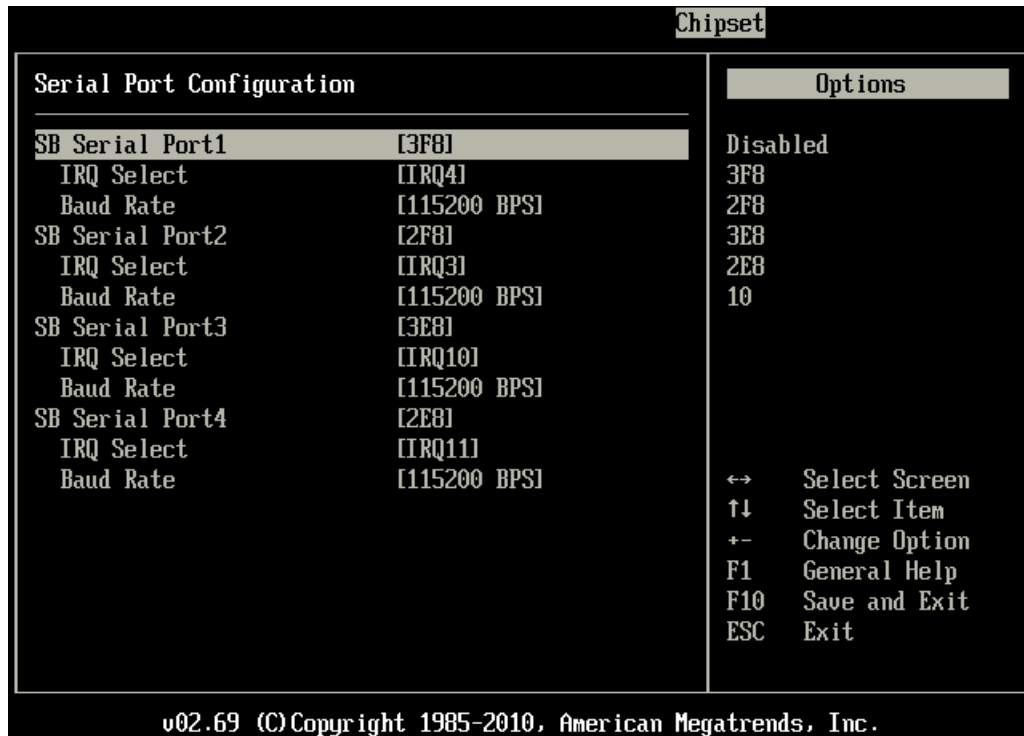

GPIOs and several configuration pins can be found in **Multi-Function Port Configuration**:

Chipset

Multi-Function Port Configuration		Options
Port0 Function	[GPIO]	
GPSPI_CS#	[IN]	0
GPSPI_CLK	[IN]	1
GPSPI_MISO	[IN]	
GPSPI_MOSI	[IN]	
FPGA_PROG_B Pin	[OUT]	
0=programming mode,1=running	[0]	
FPGA_SUSPEND	[OUT]	
0=off, 1=on	[0]	
COM1 Mode Selection	[OUT]	
0=RS232, 1=RS485	[0]	
0=RS232, 1=RS485	[0]	
GPIO Port1 Mode [GPIO]		
Bit0 Direction	[OUT]	
Output: 0=0V, 1=3.3V	[1]	
Bit1 Direction	[IN]	
Bit2 Direction	[IN]	
Bit3 Direction	[IN]	

↔ Select Screen
 ↑↓ Select Item
 +- Change Option
 F1 General Help
 F10 Save and Exit
 ESC Exit

v02.69 (C) Copyright 1985-2010, American Megatrends, Inc.

Chipset

GPIO Port1 Mode		Options
Bit0 Direction	[OUT]	
Output: 0=0V, 1=3.3V	[1]	
Bit1 Direction	[IN]	IN
Bit2 Direction	[IN]	OUT
Bit3 Direction	[IN]	
Bit4 Direction	[IN]	
Bit5 Direction	[IN]	
Bit6 Direction	[IN]	
Bit7 Direction	[IN]	
GPIO Port2 Mode [GPIO]		
Bit0 Direction	[IN]	
Bit1 Direction	[IN]	
Bit2 Direction	[IN]	
Bit3 Direction	[IN]	
Bit4 Direction	[IN]	
Bit5 Direction	[IN]	
Bit6 Direction	[IN]	
Bit7 Direction	[IN]	

↔ Select Screen
 ↑↓ Select Item
 +- Change Option
 F1 General Help
 F10 Save and Exit
 ESC Exit

v02.69 (C) Copyright 1985-2010, American Megatrends, Inc.

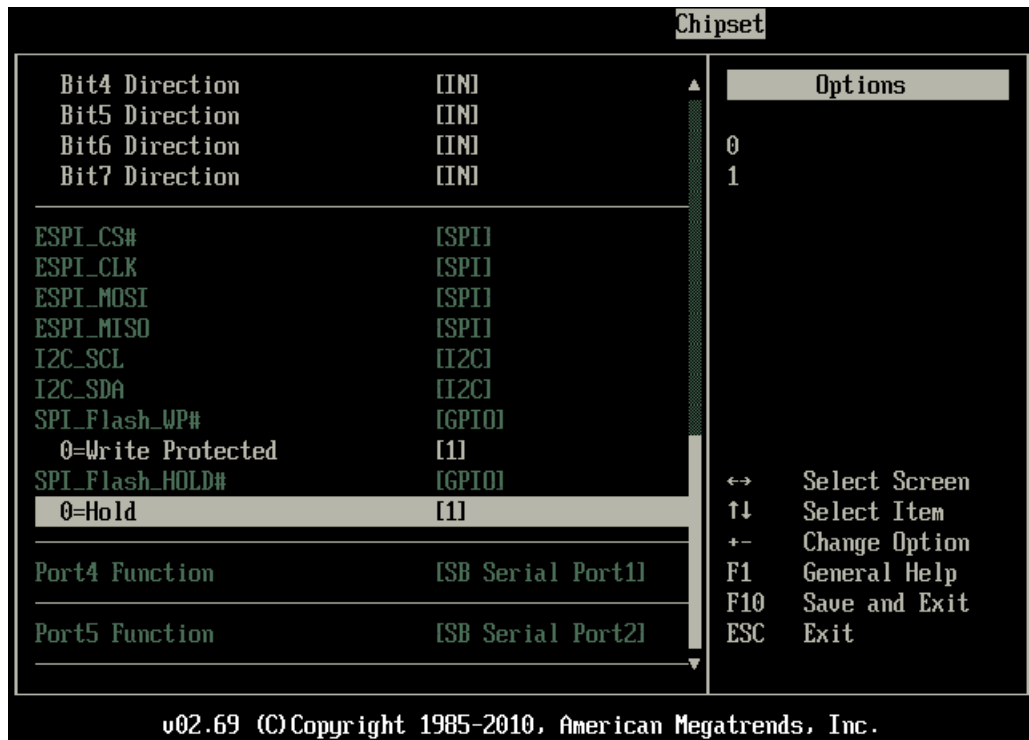

The CLR-86DX has three Watchdogs altogether. Two of them are located in the BIOS and can be configured with different times and trigger reactions:

Timer:

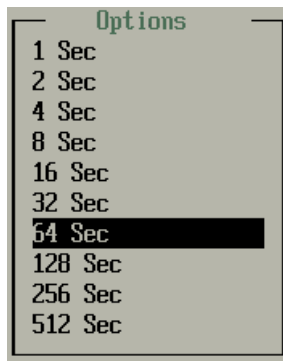

Possible signals (trigger reactions):

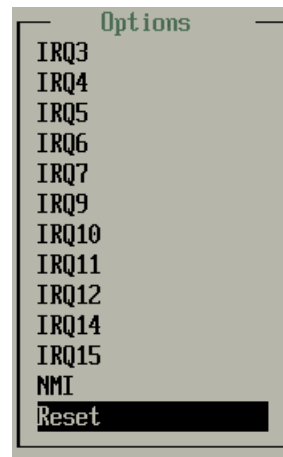

Redundancy control has two sides: a **master** and a **slave** configuration.

The **master** side in enabled state should look like:

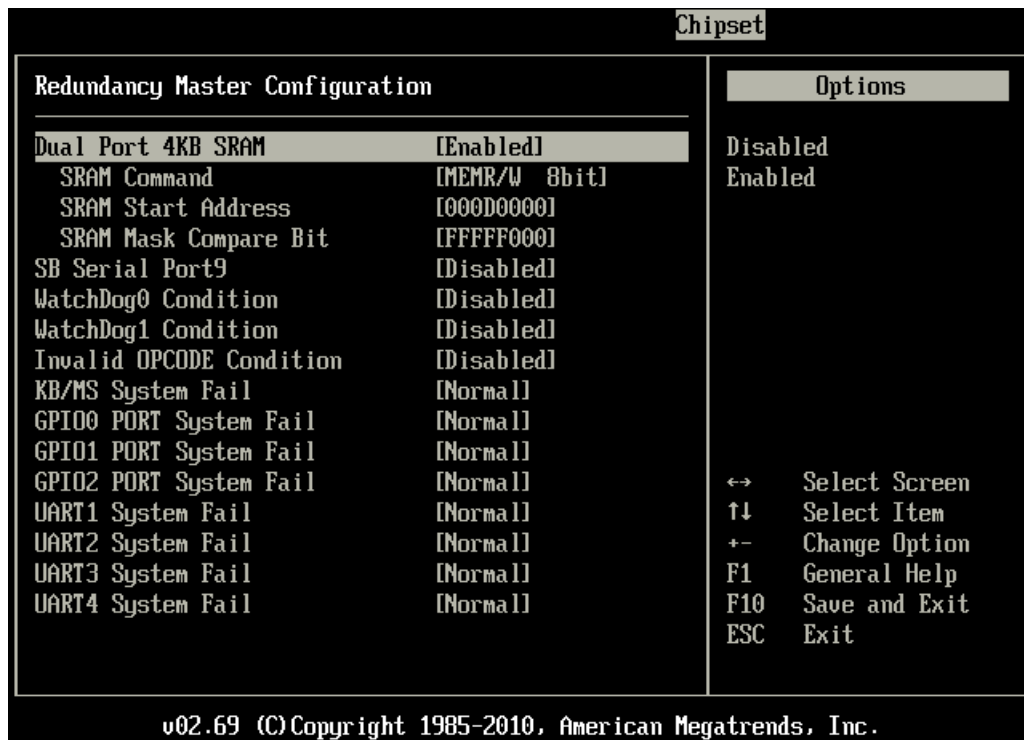

The **slave** side of the redundancy control should look (activated) like:

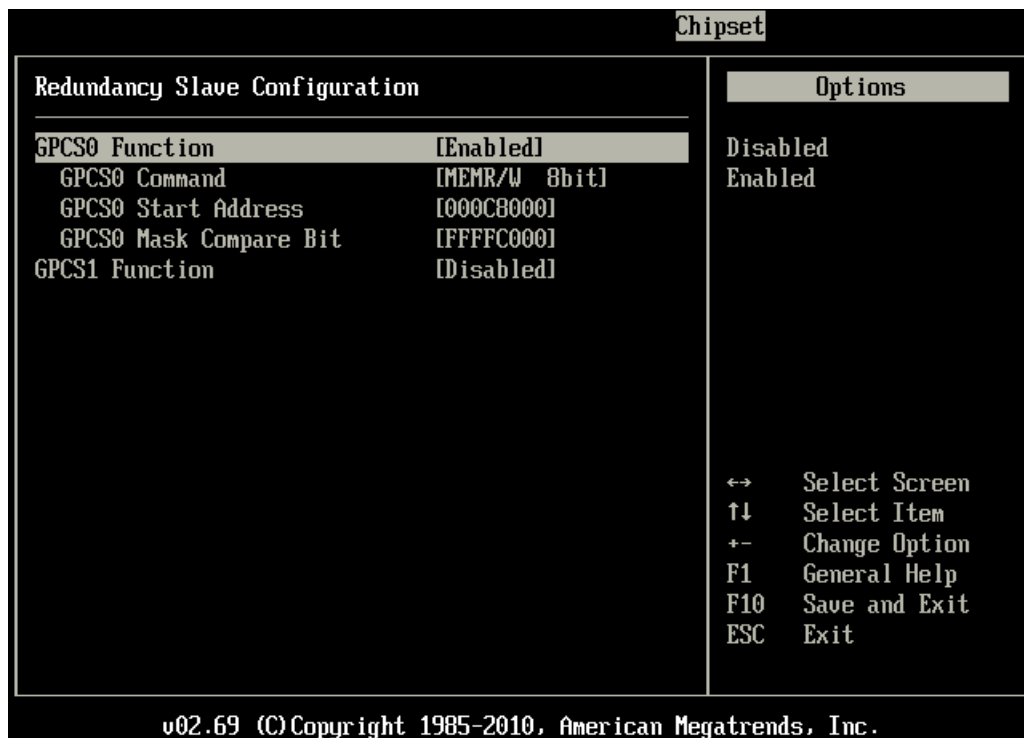

In the **Exit** tab BIOS configurations can be loaded and saved. With **Load Optimized Defaults** Lippert's default configuration can be loaded. In case the customer wants to save differing configuration it is advising to use the **Save Custom Defaults** option and then **Save Changes and Exit**.



Trouble Shooting BIOS Settings

It may happen that the BIOS is configured that the Cool LiteRunner-86DX does not start at all. To repair this, the default values of the BIOS can be automatically loaded at boot time. To load the factory defaults, the power must be switched off. Power on the system again while pressing the <END> key.

If there is a power down during an upgrade of the BIOS or if a wrong software version has been erroneously flashed, there is the possibility to flash the bios over CPU JTAG connector, please consult our support department in this case at support@lippertembedded.com.

4.4 Programming Examples

The following programming examples are made for a Linux operation system. If other operation systems are used some header files could be unnecessary or they can have different names.

The "iopl()" function is a Linux specific one, in Windows XP a tool called "porttalk" can be used instead.

Be careful with the interpretation of the "outb" order in our examples:

Linux: 'outb(value, address)'

DOS, Windows: 'outb(address, value)'

The code is meant to be compiled using gcc under Linux.

GPIOs on SUPERVISORY

The Cool LiteRunner-86DX general purpose I/O signals (GPIO) are part of the Vortex86DX. GPIO's 1x belongs to GPIO set #1, GPIO's 2x to set #2 and so on, up to set #5. The following lines show an example how to program GPIO Bank 1, whose signals are located on the SUPERVISORY connector.

Configuring and using GPIOs:

Direction register:	0x00	→all pins are input
	0xFF	→ all pins are output
Data register:	Output:	0 → 0V
		1 → +3.3V
	Input:	detects GND → bit = 0,
		open pin or VCC (+3.3V or +5.0V) will not be detected → bit =1

```
#include <sys/io.h>
#include <stdio.h>

//GPIO registers:
#define GPIO1X_DAT 0x79 //gpio port 1 data
#define GPIO2X_DAT 0x7A //gpio port 2 data
#define GPIO1X_DIR 0x99 //gpio port 1 direction
#define GPIO2X_DIR 0x9A //gpio port 2 direction

int main()
{
    if(iopl(3) != 0)
    {
        printf("IOPL error\n");
        return 1;
    }
    outb(0xff,GPIO1X_DIR); //set all pins of gpio port 1 to output
    outb(0x55,GPIO1X_DAT); //write out 0x55 to gpio port 1
    return 0;
}
```



Note:

Please note that this source code example is done for a system running with Linux. For other operation system it may be necessary to adapt the source code regarding include files or headers and the syntax of I/O out commands because Linux is using outb(value, address) instead of outb(address, value).

Watchdog

There are 3 Watchdogs available. WDT0 and WDT1 are provided by the Vortex86DX. Additionally the SMC contains a third Watchdog.

WDT0 example:

```
#include <sys/io.h>
#include <stdio.h>

#define WDT0_INDEX 0x22
#define WDT0_DATA 0x23

int main()
{
    unsigned int wdog_time = (0x20L * 0x500L);
    unsigned char trig=0, wdog_en=0, reset_cntr=0;
    if (iop1(3) != 0)
    {
        printf("IOPL error\n");
        return 1;
    }
    //Unlock sequence
    outb(0x13, WDT0_INDEX);
    outb(0xC5, WDT0_DATA);
    //set time counter register: 0x3b, 0x3a, 0x39
    outb(0x3b, WDT0_INDEX); //D23...D16
    outb((wdog_time >> 16) & 0xFF, WDT0_DATA);
    outb(0x3a, WDT0_INDEX); //D15...D8
    outb((wdog_time >> 8) & 0xFF, WDT0_DATA);
    outb(0x39, WDT0_INDEX); //D7...D0
    outb(wdog_time & 0xFF, WDT0_DATA);
    //set trigger: 0x38
    outb(0x38, WDT0_INDEX);
    trig = inb(WDT0_DATA);
    trig &= 0x0F;
    trig |= 0xD0; //0xD0 = system reset
    outb(0x38, WDT0_INDEX);
    outb(trig, WDT0_DATA);
    //enable wdog: 0x37
    outb(0x37, WDT0_INDEX);
    wdog_en = inb(WDT0_DATA);
    wdog_en |= 0x40; //bit6 = 1 --> enable WDT0
    outb(0x37, WDT0_INDEX);
    outb(wdog_en, WDT0_DATA);
    printf("Watchdog active, resetting counter, Press CLRT+C to stop resetting\n");
    //reset counter: 0x3C
    while(1)
    {
        outb(0x3C, WDT0_INDEX);
        reset_cntr = inb(WDT0_DATA);
        reset_cntr |= 0x40; //bit6 = 1 --> reset timer counter
        outb(0x3C, WDT0_INDEX);
        outb(reset_cntr, WDT0_DATA);
    }
    //Lock sequence
    outb(0x13, WDT0_INDEX);
    outb(0x00, WDT0_DATA);
    return 0;
}
```

WDT1 example:

```
#include <sys/io.h>
#include <stdio.h>

int main()
{
    unsigned int wdog_time = (0x20L * 0x500L);
    unsigned char trig=0, wdog_en=0, reset_cntr=0;
    if (iopl(3) != 0)
    {
        printf("IOPL error\n");
        return 1;
    }
    //set time counter register: 0x6c, 0x6b, 0x6a
    outb((wdog_time >> 16) & 0xFF, 0x6c); //D23...D16
    outb((wdog_time >> 8) & 0xFF, 0x6b); //D15...D8
    outb(wdog_time & 0xFF, 0x6a); //D7...D0
    //set trigger: 0x69
    trig = inb(0x69);
    trig &= 0x0F;
    trig |= 0xD0; //0xD0 = system reset
    outb(trig, 0x69);
    //enable wdog: 0x68
    wdog_en = inb(0x68);
    wdog_en |= 0x40; //bit6 = 1 --> enable WDT0
    outb(wdog_en, 0x68);
    printf("Watchdog active, resetting counter, Press CTRL+C to stop resetting\n");
    //reset timer counter : 0x67
    while(1)
    {
        reset_cntr = inb(0x67);
        reset_cntr |= 0x40; //bit6 = 1 --> reset counter
        outb(reset_cntr, 0x67);
    }
    return 0;
}
```



Note: Please note that this source code example is done for a system running with Linux. For other operation system it may be necessary to adapt the source code regarding include files or headers and the syntax of I/O out commands because Linux is using outb(value, address) instead of outb(address, value).

RS232 / RS485 switching

The operation mode of the serial interfaces COM1 and COM2 can be switched between RS232 and RS422/RS485. Therefore you need GPIO06 and GPIO07 (GPIO port 0 bits 6 and 7).

The following example shows how to switch:

```
#include <sys/io.h>
#include <stdio.h>
#include <stdlib.h>

#define GPIO0_DATA 0x78
#define GPIO0_DIR 0x98

//GPIO06 defines RS mode of COM1:
#define COM1_RS232 0x00 //GPIO06=0 --> RS232
#define COM1_RS485 0x40 //GPIO06=1 --> RS485
//GPIO07 defines RS mode of COM2:
#define COM2_RS232 0x00 //GPIO07=0 --> RS232
#define COM2_RS485 0x80 //GPIO07=1 --> RS485

int main()
{
    unsigned char dir=0, data=0;
    if(iopl(3) != 0)
    {
        printf("IOPL error\n");
        return 1; //seems, you are not root!
    }
    dir = inb(GPIO0_DIR); //get direction bits of GPIO bank 0
    outb(dir|0xC0, GPIO0_DIR); //set GPIO06 and GPIO07 to output

    data = inb(GPIO0_DATA);
    data &= 0x3F; //reset GPIO06 and GPIO07 to 0
    data |= COM1_RS485 | COM2_RS232; //set modes for COM1(RS485) and COM2(RS232)
    outb(data, GPIO0_DATA);
    return 0;
}
```



Note: Please note that this source code example is done for a system running with Linux. For other operation system it may be necessary to adapt the source code regarding include files or headers and the syntax of I/O out commands because Linux is using outb(value, address) instead of outb(address, value).

4.5 Drivers

Software drivers for IDE/SD, Ethernet and the additional Mini-PCI VGA card are available for the Cool LiteRunner-86DX.

These drivers can be downloaded from LiPPERT's website <http://www.lippertembedded.com>. Follow the installation instructions that come with the drivers.

5 Address Maps

This section describes the layout of the CPU memory and I/O address spaces.



Note Depending on enabled or disabled functions in the BIOS, other or more resources may be used

5.1 Memory Address Map

Address	Description
0000:0000-9000:FFFF	System RAM
A000:0000-A000:FFFF	EGA/VGA Video Memory
B000:0000-B000:7FFF	MDA RAM, Hercules graphics display RAM
B000:8000-B000:FFFF	CGA display RAM
C000:0000-C000:7FFF	EGA/VGA BIOS ROM
C000:8000-C000:FFFF	Boot ROM enable
D000:0000-D700:FFFF	Free
D800:0000-DB00:FFFF	SPI FLASH Emulation Floppy A Enable
DC00:0000-DF00:FFFF	Free
E000:0000-E000:FFFF	USB Legacy SCSI ROM space
F000:0000-F000:FFFF	Motherboard BIOS

5.2 I/O Address Map

The system chipset implements a number of registers in I/O address space. These registers occupy the following map in the I/O space:

Address Range (hex)	Description
0000h - 000Fh	DMA 8237-1
0010h - 0017h	COM 9
0018h - 001Fh	Empty
0020h - 0021h	PIC 8259-1
0022h - 0023h	6117D configuration port
0024h - 002Dh	Empty
002Eh - 002Fh	Forward to LPC BUS
0030h - 003Fh	Empty
0040h - 0043h	Timer counter 8254
0044h - 0047h	Empty
0048h - 004Bh	PWM counter 8254
004Ch - 004Dh	Empty
004Eh - 004Fh	Forward to LPC BUS
0050h - 005Fh	Empty
0060h	Keyboard data port
0061h	Port B + NMI control port
0062h - 0063h	8051 download 4K address counter
0064h	Keyboard status port
0065h	WatchDog0 reload counter
0066h	8051 download 8bit data port
0067h	WatchDog1 reload counter
0068h - 006Dh	WatchDog1 control register
006Eh - 006Fh	Empty
0070h - 0071h	CMOS RAM port
0072h - 0075h	MTBF counter
0076h - 0077h	Empty
0078h - 007Ch	GPIO port 0,1,2,3,4 default setup
007Dh - 007Fh	Empty
0080h - 008Fh	DMA page register
0090h - 0091h	Empty
0092h	System control register
0093h - 0097h	Empty
0098h - 009Ch	GPIO direction control
00A0h - 00A1h	PIC 8259-2
00A2h - 00BFh	Empty
00C0h - 00DFh	DMA 8237-2
00E0h - 00FFh	Empty
0100h - 0101h	GPCS1 default setting address
0170h - 0177h	IDE1 (IRQ 15)
01F0h - 01F7h	IDE0 (IRQ 14)
0220h - 0227h	COM8 Forward to LPC BUS
0228h - 022Fh	COM7 Forward to LPC BUS
0238h - 023Fh	COM6 Forward to LPC BUS
0278h - 027Fh	Printer port (IRQ 7, DMA 0)

02E8h - 02EFh	COM4 (IRQ 11)
02F8h - 02FFh	COM2 (IRQ 3)
0338h - 033Fh	COM5 Forward to LPC BUS
0376h	IDE1 ATAPI device control write only register
03E8h - 03Efh	COM3 (IRQ 10)
03F0h - 03F7h	Floppy Disk (IRQ 6, DMA 2)
03F6h	IDE0 ATAPI device control write only register
03F8h - 03FFh	COM1 (IRQ 4)
0480h - 048Fh	DMA High page register
0490h - 0499h	Instruction counter register
04D0h - 04D1h	8259 Edge,/ level control register
0CF8h - 0CFFh	PCI configuration port
D400h - D4FFh	on board LAN
FC00h - FC05h	SPI Flash BIOS control register
FC08h - FC0Dh	External SPI BUS control register (output pin configurable GPIO3[0-3])

5.3 Interrupts

IRQ	System Resource
0	System Timer
1	Keyboard Controller
2	Cascade for IRQ8 - 15
3	Serial Port 2 or PC/104 bus
4	Serial Port 1 or PC/104 bus
5	USB / Ethernet 10/100M LAN or PC/104 bus
6	USB or PC/104 bus
7	Reserved, not useable for external devices
8	Real Time Clock
9	USB/Serial Port 9 or PC/104 bus
10	Serial Port 3 or PC/104 bus
11	Serial Port 4 or PC/104 bus
12	Mouse or PC/104 bus
13	Math Coprocessor
14	Hard Disk Controller#1
15	USB/Hard Disk Controller#2 or PC/104 bus



Note Depending on the BIOS settings it is possible to reserve several IRQs for the Mini-PCI bus.
 IRQs for PC/104 extension boards can be reserved in bios setup
 Devices on the PCI and LPC bus cannot share one interrupt together!

5.4 DMA Channels

DMA	System Resource
0	Unused
1	Unused
2	Floppy Disk Controller
3	Unused
4	Unused
5	Unused
6	Unused
7	Unused

Appendix A, Contact Information

Headquarters

LiPPERT Embedded Computers GmbH
Hans-Thoma-Straße 11
68163 Mannheim
Germany

Phone	+49 621 432140
Fax	+49 621 4321430
E-mail	sales@lippertembedded.com support@lippertembedded.com
Website	www.lippertembedded.com

US Office

LiPPERT Embedded Computers, Inc.
2220 Northmont Parkway, Suite 250
Duluth, GA 30096
USA

Phone	+1 (770) 295 0031
Fax	+1 (678) 417 6273
E-mail	ussales@lippertembedded.com support@lippertembedded.com
Website	www.lippertembedded.com

Appendix B, Additional Information

B.1 Additional Reading

DMP Vortex86DX Datasheet and additional material:

<http://www.dmp.com.tw/tech/vortex86dx/>

GPS uBlox LEA-5H Datasheets:

<http://www.ublox.com/en/gps-modules/pvt-modules/lea-5h.html>

FPGA Xilinx Spartan -3A Series FPGA Datasheets and User Guides:

<http://www.xilinx.com/support/documentation/spartan-3a.htm>

B.2 PC/104

A copy of the latest PC/104 can be obtained from the PC/104 Consortium's website at <http://www.pc104.org>

Appendix C, Getting Help

Should you have technical questions that are not covered by the respective manuals, please contact our support department at support@lippertembedded.com .

Please allow one working day for an answer!

Technical manuals as well as other literature for all LiPPERT products can be found in the *Products* section of LiPPERT's website www.lippertembedded.com. Simply locate the product in question and follow the link to its manual.

Returning Products for Repair

To return a product to LiPPERT for repair, you need to get a Return Material Authorization (RMA) number first. Please print the RMA Request Form from <http://www.lippertembedded.com/service/repairs.html> fill in the blanks and fax it to +49 621 4321430. We'll return it to you with the RMA number.

Deliveries without a valid RMA number are returned to sender at his own cost!

LiPPERT has a written Warranty and Repair Policy, which can be retrieved from <http://www.lippertembedded.com/service/warranty.html>

It describes how defective products are handled and what the related costs are. Please read this document carefully before returning a product.

Appendix D, Revision History

Filename	Date	Edited by	Change
TME-104-CLR-86DX-R0V0	2010-03-09	MS	preliminary draft
TME-104-CLR-86DX-R0V1	2010-07-07	MS/MF	Update to new layout of board, Minor changes
TME-104-CLR-86DX-R0V2	2010-08-02	MF	Minor changes
TME-104-CLR-86DX-R0V3	2011-05-17	MS	Minor changes, BIOS section
TME-104-CLR-86DX-R1V0	2011-06-29	MF	Ch. 4.2 added Board specific LEMT functions Ch.5.3 IRQ7 reserved and not useable
TME-104-CLR-86DX-R1V1	2011-07-07	MS	Minor changes